



# DMP8 Dew Point and Temperature Probe

For Pressurized Pipelines



## Features

- Dew point measurement range  
-70 ... +80 °C (-94 ... +176 °F)  $T_{d/f}$
- Dew point measurement accuracy  
up to  $\pm 2$  °C ( $\pm 3.6$  °F)  $T_{d/f}$
- Operating pressure of probe head  
0 ... 4 MPa (0 ... 40 bar)
- Adjustable installation depth
- Tolerates condensation, oils, dust,  
and most chemicals
- Sensor purge provides superior  
chemical resistance
- Modbus RTU over RS-485
- Compatible with Indigo  
transmitters and Insight PC  
software
- Traceable calibration certificate

Vaisala DRYCAP® Dew Point and Temperature Probe DMP8 is designed for industrial low-humidity applications such as industrial drying, compressed air systems, and semiconductor industry. It can be installed in a 1/2" NPT or ISO thread with adjustable insertion depth.

### Stability at Low Dew Points

The Vaisala DRYCAP® sensor is immune to particulate contamination, water condensation, oil vapor, and most chemicals. The sensor tolerates condensation and recovers perfectly if exposed to liquid water. Fast reaction time and stability make its performance unmatched also in dynamic and low dew point applications. Outstanding stability provides a long calibration interval.

### Chemical Purge Minimizes Effects of Contaminants

In environments with high concentrations of chemicals and cleaning agents, the chemical purge option helps to maintain measurement accuracy between calibration intervals.

The chemical purge involves heating the sensor to remove harmful chemicals. The function can be initiated manually or programmed to occur at set intervals.

### Easy Installation

Thanks to its sliding sealing, it is easy to adjust the installation depth of the DMP8 probe head.

An optional ball-valve installation kit allows for inserting or detaching the probe from a pressurized line.

### Flexible Connectivity

The probe is compatible with Vaisala Indigo series of transmitters, and it can be used as a standalone digital Modbus RTU transmitter over RS-485 serial bus.

For easy-to-use access to field calibration, device analytics, and configuration functionality, the probe can be connected to Vaisala Insight software for Windows®: see [www.vaisala.com/insight](http://www.vaisala.com/insight).

# Technical Data

## Measurement Performance

### Dew Point

Sensor	DRYCAP® 180M
Measurement range	-70 ... +80 °C (-94 ... +176 °F) T <sub>d/f</sub>
Measurement range for continuous use	-70 ... +45 °C (-94 ... +113 °F) T <sub>d/f</sub>
Accuracy up to 20 bar/290 psia	±2 °C/±3.6 °F T <sub>d/f</sub> See accuracy graph.
Accuracy, 20 ... 40 bar/290 ... 580 psia	Additional inaccuracy +1 °C T <sub>d/f</sub>
Response time 63 % [90 %] <sup>1)</sup>	
From dry to wet	5 s [15 s]
From wet to dry	45 s [8 min]

### Temperature

Measurement range	0 ... +80 °C (+32 ... +176 °F)
Accuracy	±0.2 °C at room temperature
Temperature sensor	Pt100 RTD Class F0.1 IEC 60751

### Relative Humidity

Measurement range	0 ... 70 %RH
Accuracy (RH <10 %RH, at +20 °C)	±0.004 %RH + 20% of reading

### Concentration by Volume (ppm)

Measurement range (typical)	10 ... 2500 ppm
Accuracy (at +20 °C, 1 bar)	1 ppm + 20% of reading

1) Tested with sintered filter.

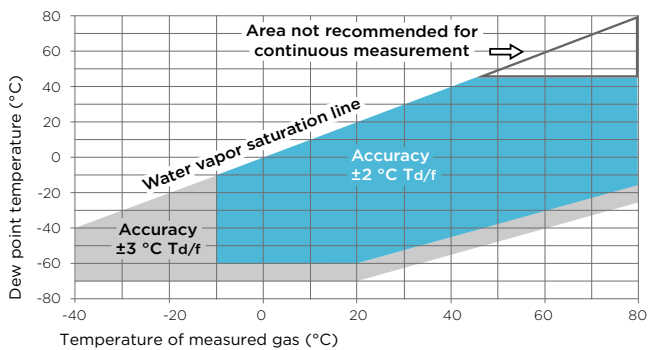

Dew Point Accuracy vs. Measurement Conditions

## Inputs and Outputs

Operating voltage	15 ... 30 VDC
Current consumption	10 mA typical, 500 mA max.
Digital output	RS-485, non-isolated
Protocols	Modbus RTU

### Output Parameters

Relative humidity, temperature, dew point temperature, absolute humidity, mixing ratio, water concentration, water vapor pressure, water vapor saturation pressure, enthalpy

## Operating Environment

Operating temperature for probe head	-40 ... +80 °C (-40 ... +176 °F)
Operating temperature for probe body	-40 ... +80 °C (-40 ... +176 °F)
Storage temperature	-40 ... +80 °C (-40 ... +176 °F)
Operating pressure for probe head	0 ... 40 bar (0 ... 580 psia)
Measurement environment	For air, nitrogen, hydrogen, argon, helium, oxygen <sup>1)</sup> , and vacuum
IP rating	IP66
EMC compatibility	EN61326-1, Industrial environment
Mechanical durability of probe head	Up to +180 °C (+356 °F) Up to 70 bar/1015 psia

1) Consult Vaisala if other chemicals are present. Consider safety regulations with flammable gases.

## Mechanical Specifications

Connector	M12 5-pin A-coded male
Weight	512 g (18.1 oz)
Probe cable length	2 m (6.56 ft)
<b>Materials</b>	
Probe	AlSi316L
Probe body	AlSi316L
Cable jacket	FEP

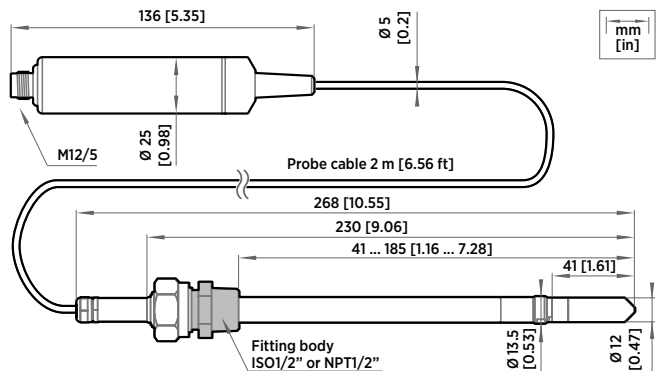

DMP8 Dimensions

## Accessories

Fitting body R 1/2" ISO with leak screw	ISOFITBODASP
Fitting body R 1/2" ISO (no leak screw)	DRW212076SP
Fitting body NPT1/2" (no leak screw)	NPTFITBODASP
Sampling cell	DMT242SC
Sampling cell with Swagelok connectors	DMT242SC2
Ball valve set for pressurized pipelines	BALLVALVE-1
Duct installation flange for R1/2" ISO thread	DM240FASP
Thread adapter ISO 1/2" to NPT 1/2"	210662SP
Blind plug ISO 1/2"	218773
USB PC connection cable <sup>1)</sup>	242659

1) Vaisala Insight software for Windows available at [www.vaisala.com/insight](http://www.vaisala.com/insight)



[www.vaisala.com](http://www.vaisala.com)

Published by Vaisala | B211794EN-C © Vaisala Oyj 2020

All rights reserved. Any logos and/or product names are trademarks of Vaisala or its individual partners. Any reproduction, transfer, distribution or storage of information contained in this document is strictly prohibited. All specifications – technical included – are subject to change without notice.