

USER'S GUIDE

Vaisala HUMICAP[®] Humidity and Temperature Transmitter Series HMT120

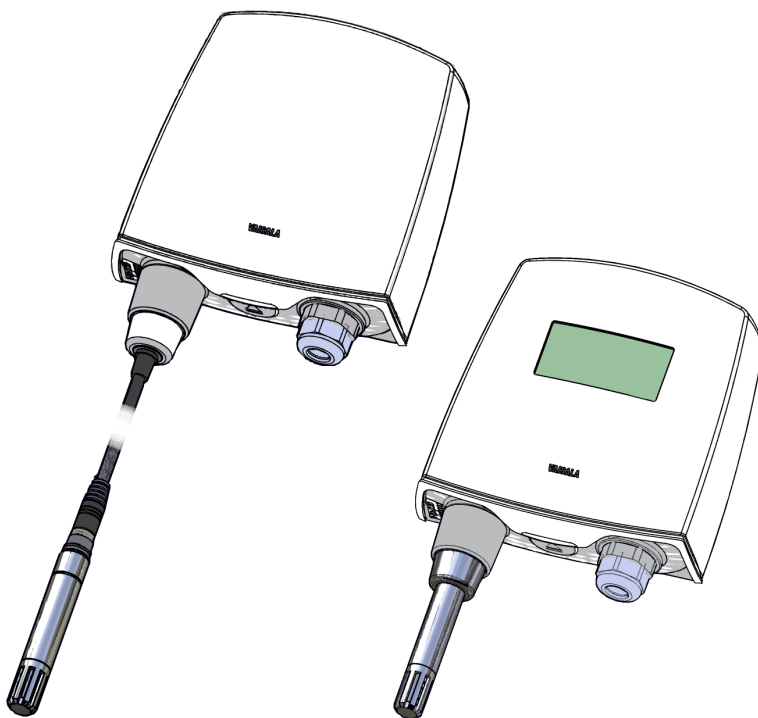

PUBLISHED BY

Vaisala Oyj
P.O. Box 26
FI-00421 Helsinki
Finland

Phone (int.): +358 9 8949 1
Fax: +358 9 8949 2227

Visit our Internet pages at www.vaisala.com.

© Vaisala 2013

No part of this manual may be reproduced, published or publicly displayed in any form or by any means, electronic or mechanical (including photocopying), nor may its contents be modified, translated, adapted, sold or disclosed to a third party without prior written permission of the copyright holder. Translated manuals and translated portions of multilingual documents are based on the original English versions. In ambiguous cases, the English versions are applicable, not the translations.

The contents of this manual are subject to change without prior notice.

This manual does not create any legally binding obligations for Vaisala towards customers or end users. All legally binding obligations and agreements are included exclusively in the applicable supply contract or the General Conditions of Sale and General Conditions of Service of Vaisala.

Table of Contents

CHAPTER 1	
GENERAL INFORMATION	5
About This Manual	5
Contents of This Manual	5
Version Information	6
Related Manuals	6
Documentation Conventions	6
Safety	7
ESD Protection	7
Recycling	7
Regulatory Compliances	8
Patent Notice	8
Trademarks	8
License Agreement	8
Warranty	8
CHAPTER 2	
PRODUCT OVERVIEW	9
Introduction to the HMT120 Humidity and Temperature Transmitter	9
Accessories	10
Fixed and Remote Probe Models	10
Optional Display	10
Interchangeable Probe	10
Constant Output Probe	11
Transmitter Components	12
CHAPTER 3	
INSTALLATION	13
Opening the Transmitter Cover	13
Mounting	14
Wall Mounting	14
Installation with Rain Shield	15
Installation with Radiation Shield	16
Duct Installation Kit	17
Probe Assembly with Duct Installation Kit	18
Drilling Instructions for Duct Installation Kit	18
Probe Mounting Flange	19
Probe Mounting Clamp	20
Connections	21
CHAPTER 4	
SERVICE PORT	23
Using the Service Port	23
Installing the Driver for the USB Cable	23

Terminal Application Settings	24
List of Serial Commands	26
Device Information and Status	27
Show Device Information.....	27
Set/Show Available Quantities	28
Set/Show Calibration Date	28
Set/Show Calibration Information	29
Show Analog Output Status	30
Show System Information	31
Show Firmware Version	31
Serial Line Output Commands	31
Start Continuous Outputting	31
Stop Continuous Outputting	32
Set/show Output Interval	32
Output a Reading Once.....	32
Calibration Commands	33
Calibrate Humidity Measurement	33
Restore Probe RH Factory Calibration	34
Calibrate Temperature Measurement	34
Restore Probe T Factory Calibration	35
Calibrate Analog Output	35
Configuring Serial Line Operation	36
Set/Show Serial Line Settings	36
Set/Show Terminal Echo	36
Set/Show Serial Interface Mode.....	37
Configuring Measurement Parameters	37
Set/Show Environmental Parameters	37
Configuring Analog Output	38
Set/show Analog Output Error Levels	38
Set/show Analog Output Quantity and Scaling	38
Test Analog Outputs.....	40
Other Commands.....	41
Set/show Displayed Quantities.....	41
Set/show Output Formatting.....	42
Display Command List.....	43
Display Active Errors	43
Save Changed Settings.....	43
Restore Saved Settings.....	44
Reset Transmitter	44
Restore Factory Settings	44
Set/show Output Unit.....	45
CHAPTER 5	
MAINTENANCE.....	47
Replacing the HUMICAP[®] Sensor	47
Fixed and Remote Probe Models.....	47
Removing and Fastening the Probe	48
Fixed Probe Model	48
Remote Probe Model.....	49
Calibration and Adjustment.....	50
HMT120 Push-Button Calibration.....	50
Humidity and Temperature Adjustment.....	51
Adjustment with HM70.....	54

Field Checking and Adjustment Using a Calibrated Reference Probe	55
One-Point Adjustment Using a Calibrator	55
Two-Point Adjustment Using a Calibrator	56
LiCl-NaCl Adjustment.....	57
Temperature Field Check and Adjustment by Using a Calibrated Reference Probe	58
Adjustment with HMI41	59
Connections and Selecting the Calibrator Function.....	60
Offset and Gain Adjustments	61
HMI41 as a Reference Meter.....	62
HMI41 as a Terminal.....	63
Troubleshooting	64
Analog Output Tests	65
CHAPTER 6	
TROUBLESHOOTING	67
Error Codes.....	67
Solving Typical Problems.....	68
Analog Output Error Notification.....	69
Technical Support	69
CHAPTER 7	
TECHNICAL DATA	71
Options and Accessories	73
Transmitter Dimensions	74
APPENDIX A	
CALCULATION FORMULAS	77
Dewpoint Temperature	78
Dew/frostpoint Temperature	78
Mixing Ratio	79
Absolute Humidity.....	79
Enthalpy	79
Saturation Vapor Pressure.....	80
Water Vapor Pressure.....	81
Accuracies of Calculated Variables	81
Accuracy of Dewpoint Temperature °C.....	81
Accuracy of Mixing Ratio g/kg (Ambient Pressure 1013 mbar)	81
Accuracy of Wet Bulb Temperature °C	82
Accuracy of Absolute Humidity g/m ³	82
INDEX	83

List of Figures

Figure 1	HMT120 Components	12
Figure 2	Opening the Transmitter Cover	13
Figure 3	HMT120 Wall Mounting	14
Figure 4	HMT120 Installation with Rain Shield.....	15
Figure 5	Installation of the Probe with Radiation Shield.....	16
Figure 6	Probe Installation with the Duct Installation Kit	17
Figure 7	Assembly of the Probe with Duct Installation Kit.....	18
Figure 8	Drilling Instructions	18
Figure 9	Optional Probe Mounting Flange.....	19
Figure 10	Optional Probe Mounting Clamp	20
Figure 11	HMT120 Component Board.....	21
Figure 12	Isolated Current-Loop Wiring.....	22
Figure 13	PuTTY Terminal Application.....	25
Figure 14	Removing the Humidity Probe (Fixed Probe Model)	48
Figure 15	Removing the Humidity Probe (Remote Probe Model)	49
Figure 16	Adjustment Buttons	50
Figure 17	Location of the MI70 Probe and Cable Connector Ports.....	54
Figure 18	Example of the MI70 Adjustment Menu	56
Figure 19	Example of the MI70 Adjustment Mode Graph Display.....	56
Figure 20	Location of the HMI41 Calibration Connector	59
Figure 21	HMT120 Output Current Measurement.....	65
Figure 22	Dimensions of the Fixed Probe Model in mm (inches).....	74
Figure 23	Dimensions of the Remote Probe Model in mm (inches).....	75

List of Tables

Table 1	Manual Revisions	6
Table 2	Related Manuals.....	6
Table 3	Wiring Table.....	22
Table 4	Default Serial Interface Setting.....	24
Table 5	Serial Port Commands	26
Table 6	Common Problems During Adjustment and Their Remedies ..	64
Table 7	Error Codes and Texts	67
Table 8	Troubleshooting Table.....	68
Table 9	Relative Humidity Measurement Specifications	71
Table 10	Temperature Measurement Specifications.....	71
Table 11	Operating Environment Specifications	72
Table 12	Inputs and Outputs	72
Table 13	Mechanical Specifications	72
Table 14	Options and Accessories.....	73

CHAPTER 1

GENERAL INFORMATION

This chapter provides general notes for the manual and HMT120 Series.

About This Manual

This manual provides information for installing, operating, and maintaining the Humidity and Temperature Transmitter HMT120.

Contents of This Manual

This manual consists of the following chapters:

- Chapter 1, General Information, This chapter provides general notes for the manual and HMT120 Series.
- Chapter 2, Product Overview, introduces the features, components and accessories of the HMT120 Series.
- Chapter 3, Installation, provides you with information that is intended to help you install the HMT120
- Chapter 4, Service Port, describes the service port of the HMT120.
- Chapter 5, Maintenance, provides information that is needed in basic maintenance of HMT120.
- Chapter 6, Troubleshooting, describes error messages and analog output error behavior, troubleshooting for possible problems, and provides contact information for technical support
- Chapter 7, Technical Data, provides the technical data of the HMT120.
- Appendix A, Calculation Formulas, contains the formulas used for the calculated output quantities.
- INDEX

Version Information

Table 1 **Manual Revisions**

Manual Code	Description
M211244EN-B	June 2013. This version. New probe options added. Installation and operating instructions updated.
M211244EN-A	November 2010. First version.

Related Manuals

Table 2 **Related Manuals**

Manual Code	Manual Name
M210185EN	Humidity Calibrator HMK15 User's Guide
M210297EN	Hand-held Humidity and Temperature Meter HM70 User's Guide
M210316EN	HMI41 Indicator and HMP41/45/46 Probes Operating Manual
M211060EN	HMP60 and HMP110 Series Probe User's Guide

Documentation Conventions

Throughout the manual, important safety considerations are highlighted as follows:

WARNING	Warning alerts you to a serious hazard. If you do not read and follow instructions very carefully at this point, there is a risk of injury or even death.
----------------	---

CAUTION	Caution warns you of a potential hazard. If you do not read and follow instructions carefully at this point, the product could be damaged or important data could be lost.
----------------	--

NOTE	Note highlights important information on using the product.
-------------	---

Safety

The Humidity and Temperature Transmitter HMT120 delivered to you has been tested for safety and approved as shipped from the factory. Note the following precautions:

CAUTION

Do not modify the unit. Improper modification can damage the product or lead to malfunction.

ESD Protection

Electrostatic Discharge (ESD) can cause immediate or latent damage to electronic circuits. Vaisala products are adequately protected against ESD for their intended use. It is possible to damage the product, however, by delivering electrostatic discharges when touching, removing, or inserting any objects inside the equipment housing.

To make sure you are not delivering high static voltages yourself:

- Handle ESD sensitive components on a properly grounded and protected ESD workbench.
- When an ESD workbench is not available, ground yourself to the equipment chassis with a wrist strap and a resistive connection cord.
- If you are unable to take either of the above precautions, touch a conductive part of the equipment chassis with your other hand before touching ESD sensitive components.
- Always hold component boards by the edges and avoid touching the component contacts.

Recycling



Recycle all applicable material.



Dispose of the unit according to statutory regulations. Do not dispose of with regular household refuse.

Regulatory Compliances

Vaisala HUMICAP[®] Humidity and Temperature Transmitter Series HMT120 is in conformity with the provisions of the following EU directives:

- EMC-Directive (2004/108/EC)

Conformity is shown by compliance with the following standards:

- EN 61326-1: Electrical equipment for measurement, control and laboratory use – EMC requirements – for use in industrial locations.
- EN 55022 + Am1: Information technology equipment – Radio disturbance characteristics – Limits and methods of measurement.



Patent Notice

The HMT120 is protected by the following patents and their corresponding national rights:

Finnish patent 98861, French patent 6650303, German patent 69418174, Japanese patent 3585973, UK patent 0665303, U.S. patent 5607564.

Trademarks

HUMICAP[®] is a registered trademark of Vaisala Oyj.

License Agreement

All rights to any software are held by Vaisala or third parties. The customer is allowed to use the software only to the extent that is provided by the applicable supply contract or Software License Agreement.

Warranty

Visit our Internet pages for standard warranty terms and conditions:
www.vaisala.com/warranty.

Please observe that any such warranty may not be valid in case of damage due to normal wear and tear, exceptional operating conditions, negligent handling or installation, or unauthorized modifications. Please see the applicable supply contract or Conditions of Sale for details of the warranty for each product.

CHAPTER 2

PRODUCT OVERVIEW

This chapter introduces the features, components and accessories of the HMT120 Series.

The Vaisala range of relative humidity measurement instruments covers all the applications from ventilation to process control in demanding conditions. For more information about other Vaisala relative humidity instruments, please contact your Vaisala representative or visit www.vaisala.com.

Introduction to the HMT120 Humidity and Temperature Transmitter

HMT120 measures relative humidity and temperature and converts it to analog current loop outputs. Other quantities, such as dewpoint (Td) can be calculated from the basic RH and T values according to the device configuration. HMT120 is powered with a 10 ... 30 VDC external loop voltage (20 ... 30 VDC when $R_L < 500$ ohms) and it outputs two analog current signals with nominal 4 ... 20 mA range.

HMT120 transmitter's output quantities are configurable. Available quantities for outputs are limited to two at the time. These two quantities can be used freely at any outputs (display, service port and analog current loop outputs).

Available quantities are RH, T, Td, Td/f, a, x, h, Tw, pws, and pw.

The default output quantities are set at the factory during order time. These factory preset quantity selections can be changed afterwards via service port if necessary.

The HMT120T and HMT120H models are single-parameter transmitters. The only output quantity of HMT120T is temperature. The output of the HMT120H can be configured to be any one of the humidity-related quantities (RH, Td, Td/f, a, x, h, Tw, pws and pw).

Accessories

The following accessories are optionally available:

- Duct installation kit
- Rain shield with installation kit
- Rain/solar radiation shield installation kit (for pole installation)
- Probe mounting flange
- Probe mounting clamp
- Constant output probe (HMP1100REF, gives constant RH and T values)

Fixed and Remote Probe Models

The HMT120 is available either with a fixed probe directly attached to the transmitter housing or a remote probe with different (3/5/10/20 m) cable lengths. All extension cables can be easily cascaded in order to obtain longer reach; see Options and Accessories on page 73.

Optional Display

The HMT120 is also available with an optional graphical 128*64 pixel resolution LCD display. The display shows the measurement results of selected parameters in selected units (defined at the time of ordering). The parameters are displayed simultaneously at two separate rows on the display.

Interchangeable Probe

The HMP110 relative humidity probe used in the HMT120 transmitter is fully interchangeable. You can easily remove the probe and replace it with a new one without having to adjust the transmitter. You have the following options when purchasing a new probe from Vaisala:

- Order a new probe and keep your current one.
- Order a new probe and return the old one to Vaisala (replacement probe).

NOTE

Only probes that have a compatible digital output (VDIGI mode) can be used with HMT120 transmitter. Compatible probes have the letter "V" as the first letter in their order code. The order code is written on the probe.

Constant Output Probe

The constant output probe HMP110REF is a testing accessory that can be used to check the transmitter's functions and measurement signal transfer chain all the way to the control system. The constant output probe does not measure humidity and temperature; instead, it outputs constant humidity and temperature readings.

The values output by the constant output probe are specified when ordering. These values are written on an additional label on the probe body.

The procedure for using the constant output probe is simply to replace the original probe for the duration of the testing:

1. Disconnect the normal probe from transmitter.
2. Connect the constant output probe to the transmitter.
3. Check that all used outputs (analog, display, serial line) show the correct measurement values.
4. After checking the outputs, disconnect the constant output probe and reconnect the original probe.

NOTE

The transmitter goes to the error state for a short time when the probe is changed. This is normal.

Transmitter Components

Figure 1 below illustrates the main features of HMT120. On the left is a remote probe model without display, and on the right is a fixed probe model with the optional display. The numbers and arrows indicate the main components of the transmitters.

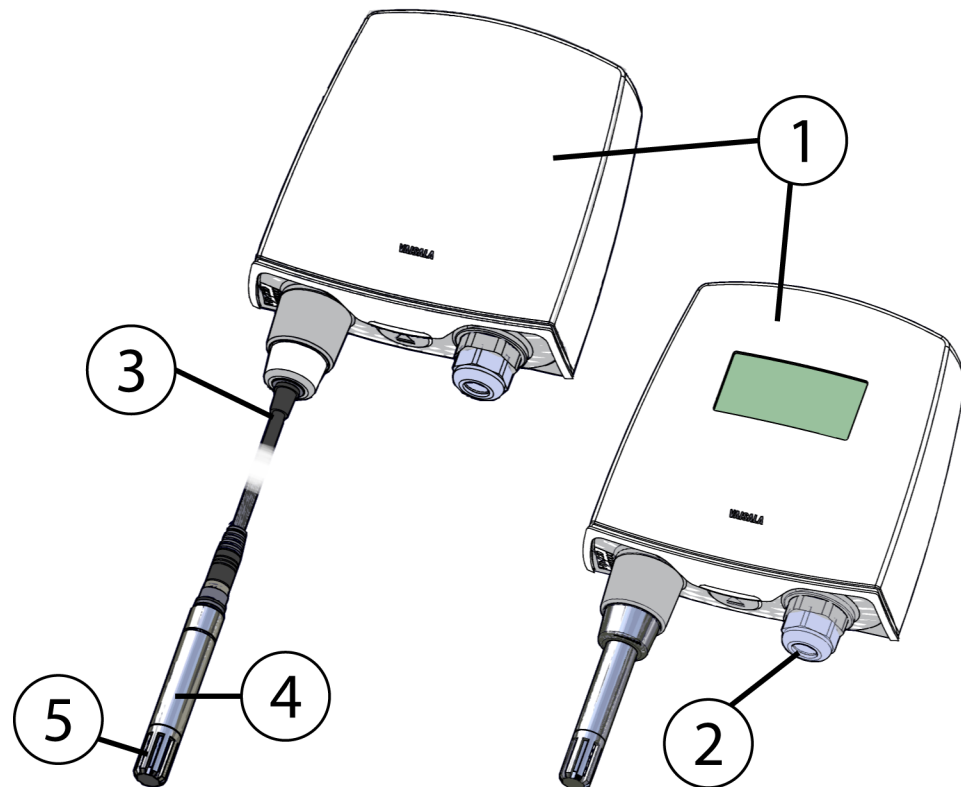

1007-001

Figure 1 HMT120 Components

The following numbers refer to Figure 1 above:

- 1 = Transmitter enclosure
- 2 = Cable bushing: cable gland, cable grommet, or conduit fitting.
- 3 = Probe cable
- 4 = HMP110 probe
- 5 = Plastic grid filter

See section Options and Accessories on page 73 for accessory parts and their numbers.

CHAPTER 3

INSTALLATION

This chapter provides you with information that is intended to help you install the HMT120.

Opening the Transmitter Cover

1. If the transmitter is not mounted already, hold it against a flat surface.
2. Push on the cover with your thumb, and pull the bottom part of the cover towards yourself.

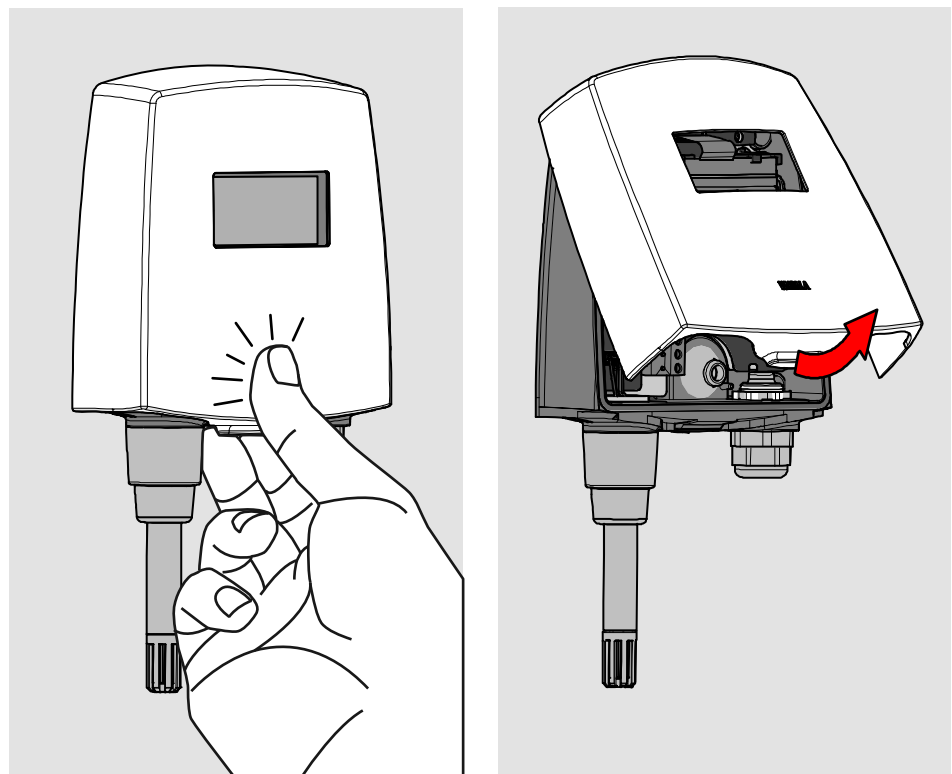

1301-019

Figure 2 Opening the Transmitter Cover

Mounting

Wall Mounting

1. Remove the transmitter cover. See section Opening the Transmitter Cover on page 13.
2. Make sure that the HMT120 Humidity and Temperature Transmitter is correctly aligned and attach it directly to the wall with up to four screws (not included in the package).

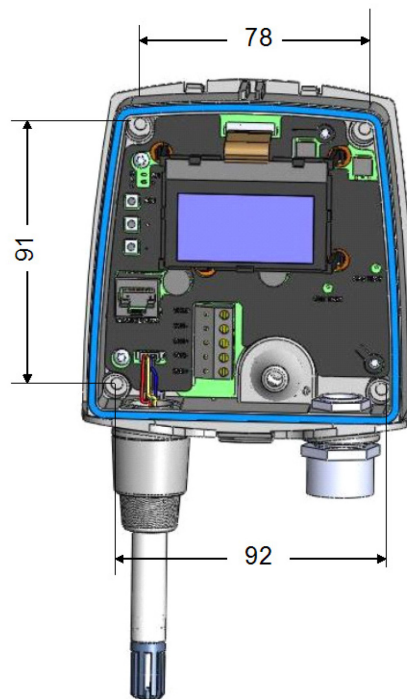

1011-149

Figure 3 HMT120 Wall Mounting

CAUTION

It is possible to damage the display when tightening the screws, as there is not much room between the upper fastening holes and the exposed display component. Be particularly careful when using a cordless drill.

NOTE

Select the size and type of the fastening screws according to the wall material (for example, wood or stone). Even though using all four screws is strongly recommended, the HMT120 enclosure fastening holes are initially covered with a thin plastic membrane, so less than four screws could be also be used without sacrificing the ingress protection (IP) class of the enclosure. The diameter of the fastening screws is typically between 3.5 and 4 mm.

Installation with Rain Shield

The installation kit with rain shield includes a metal mounting plate and a rain shield for the transmitter. Vaisala order code: 215109.

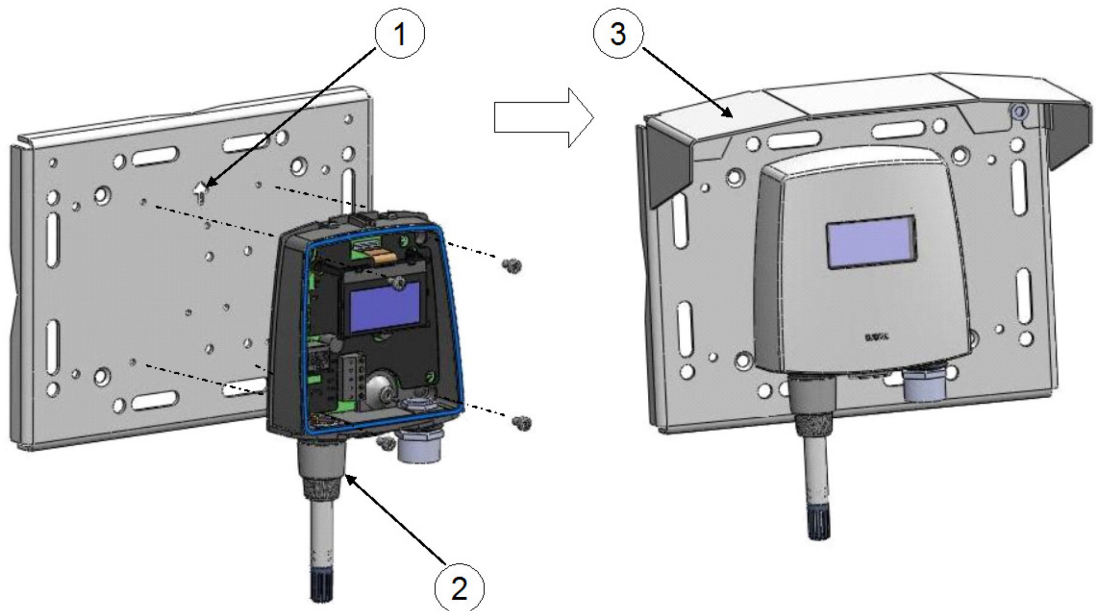

1011-150

Figure 4 HMT120 Installation with Rain Shield

1. Fasten the metal mounting plate to the wall or pole with screws (see Figure 4 above). Note the arrow on the mounting plate. Attach the mounting plate with the arrow pointing upwards.
2. Drill holes for the screws in the HMT120 frame, and fasten HMT120 Humidity and Temperature Transmitter to the metal mounting plate with four (M4) screws.
3. Fasten the rain shield to the metal mounting plate with two (M6) mounting screws.

Installation with Radiation Shield

DTR504 with probe installation kit includes a rain/solar radiation shield DTR504 and a plastic installation support for the humidity probe. Vaisala order code: DTR504A. If you already have the DTR504 shield and need only the installation support for the probe, it is available with Vaisala order code 227777.

1. Fasten the probe (item 2 in Figure 5 below) to the installation support with a cable tie (item 5).
2. Insert and attach the support to the radiation shield by tightening the plastic nut (3).
3. Attach the entire radiation shield/probe assembly to a pole mast (pole mast diameter: 30 ... 60 mm/1.2 ... 2.3") with a U-bolt and a support arm.

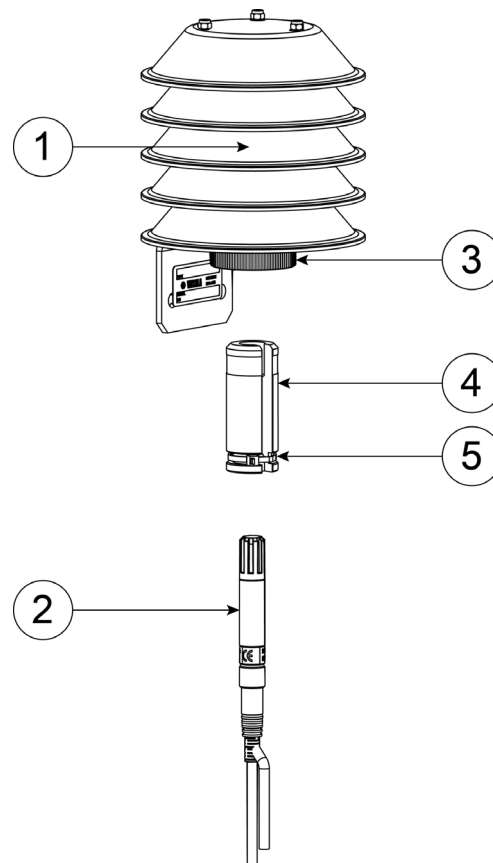

1303-034

Figure 5 Installation of the Probe with Radiation Shield

The following numbers refer to Figure 5 above:

- 1 = DTR504
- 2 = Probe
- 3 = Plastic nut
- 4 = Installation support (part no. 227777)
- 6 = Probe

Duct Installation Kit

The duct installation kit includes a plastic pipe with a flange (Vaisala order code: 215619). To install the HMP110 probe with the duct installation kit, drill a hole to the duct wall, assemble the probe to the duct installation kit, slide the probe head through the hole, and attach the flange to the duct wall with four screws. See page 18 for details.

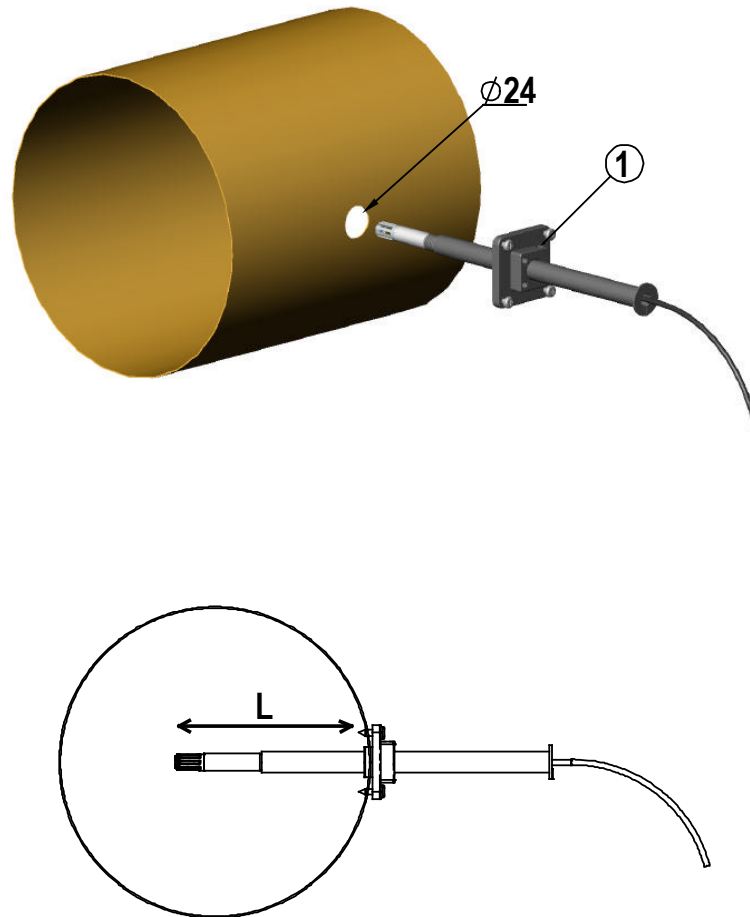

0505-176

Figure 6 Probe Installation with the Duct Installation Kit

The following explanations refer to Figure 6 above:

1 = Tension screw

Distance L can be adjusted and locked in place with the tension screw.

Probe Assembly with Duct Installation Kit

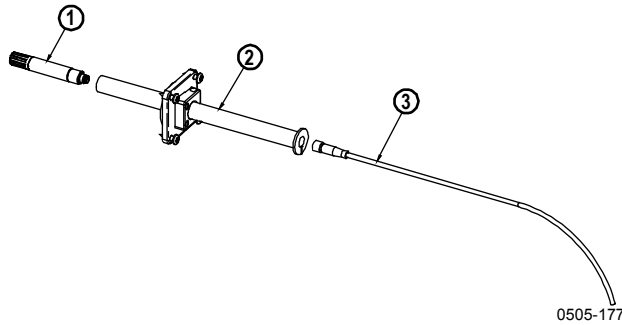

Figure 7 Assembly of the Probe with Duct Installation Kit

The following numbers refer to Figure 7 above:

- 1 = HMP110
- 2 = Duct installation kit
- 3 = Probe cable

1. Slide the probe cable through the duct installation kit plastic pipe.
2. Attach the probe cable to the HMP110 Humidity Probe.
3. Attach probe assembly to the duct.

Drilling Instructions for Duct Installation Kit

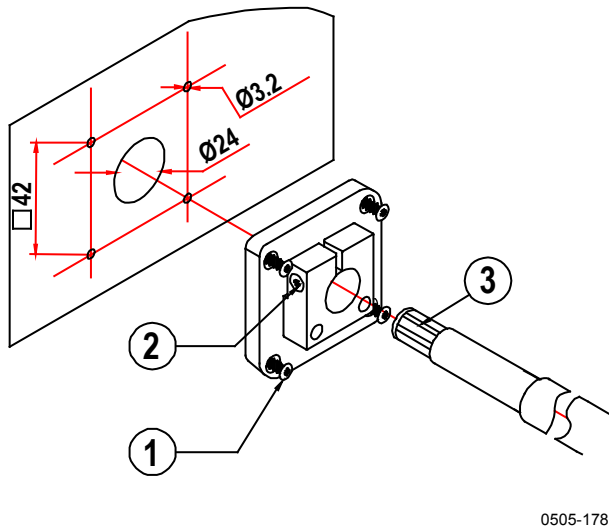

Figure 8 Drilling Instructions

The following numbers refer to Figure 8 above:

- 1 = Mounting screw
- 2 = Tension screw
- 3 = HMP110 assembled in duct installation kit plastic pipe

Drill the holes for the duct installation kit as follows:

1. Use a 24-mm drill bit to drill a hole to the duct wall for the humidity probe.
2. Drill holes for the duct installation kit mounting screws around the hole in a square arrangement, 42 mm apart from each other. Use a 3.2-mm drill bit to drill the holes for the mounting screws (four ST4.2×16-C-Z DIN 7981 screws).

Probe Mounting Flange

The probe mounting flange (Vaisala order code: 226061) is a general purpose mounting flange for 12 mm diameter probes. It can be used to hold the HMP110 probe in a through-wall installation.

NOTE

The coaxial silicone plug that is delivered with the flange is not suitable for use with the probe cable of the HMT120.

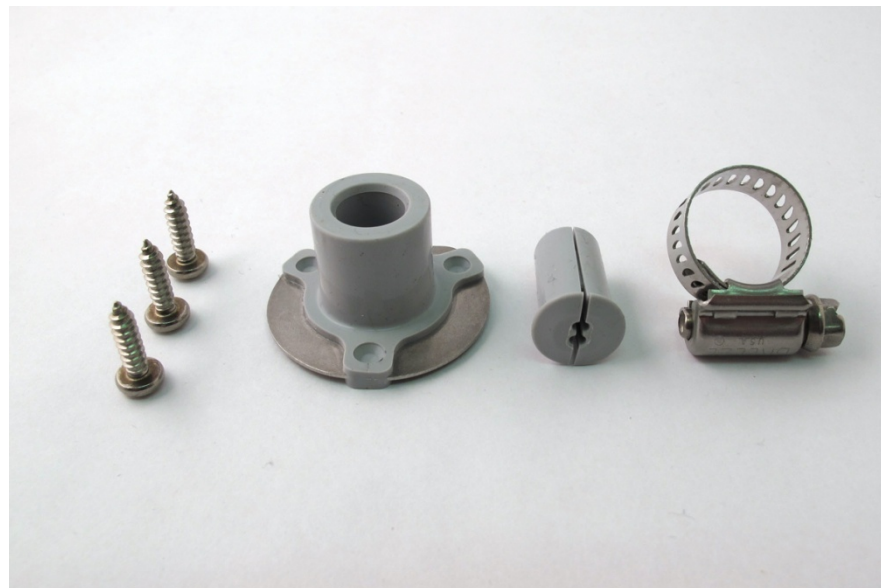

0911-109

Figure 9 Optional Probe Mounting Flange

Probe Mounting Clamp

The optional mounting clamp makes it easy to install the probe on the wall of the measurement environment. The probe can be detached for calibration simply by loosening the lower screw. You can order a single clamp (Vaisala order code 225501) or a set of 10 clamps (226067).

Installing the entire probe in the measurement environment prevents heat conduction to the sensor, and is the recommended installation method.

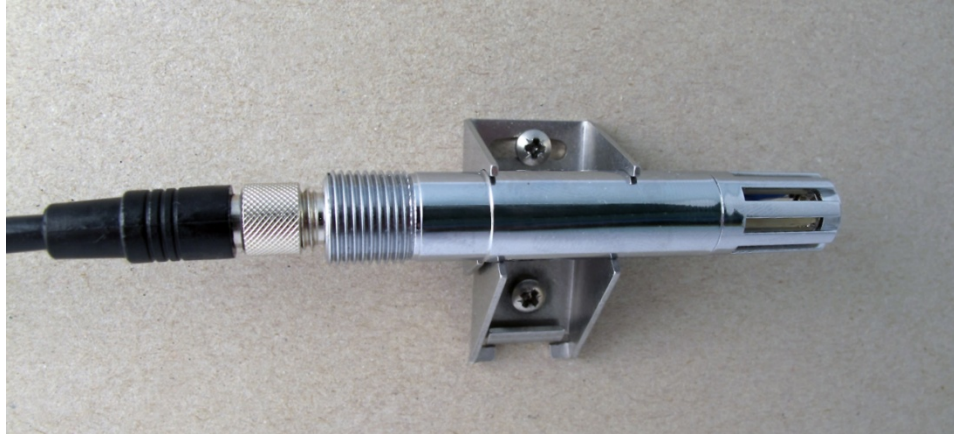

1001-138

Figure 10 **Optional Probe Mounting Clamp**

CAUTION

Attaching the probe mounting clamp to a conductive wall material should be avoided, since the potential galvanic connection to the power supplies and uncontrolled earth current loops could cause measurement errors or even damage to the HMT120 transmitter.

Connections

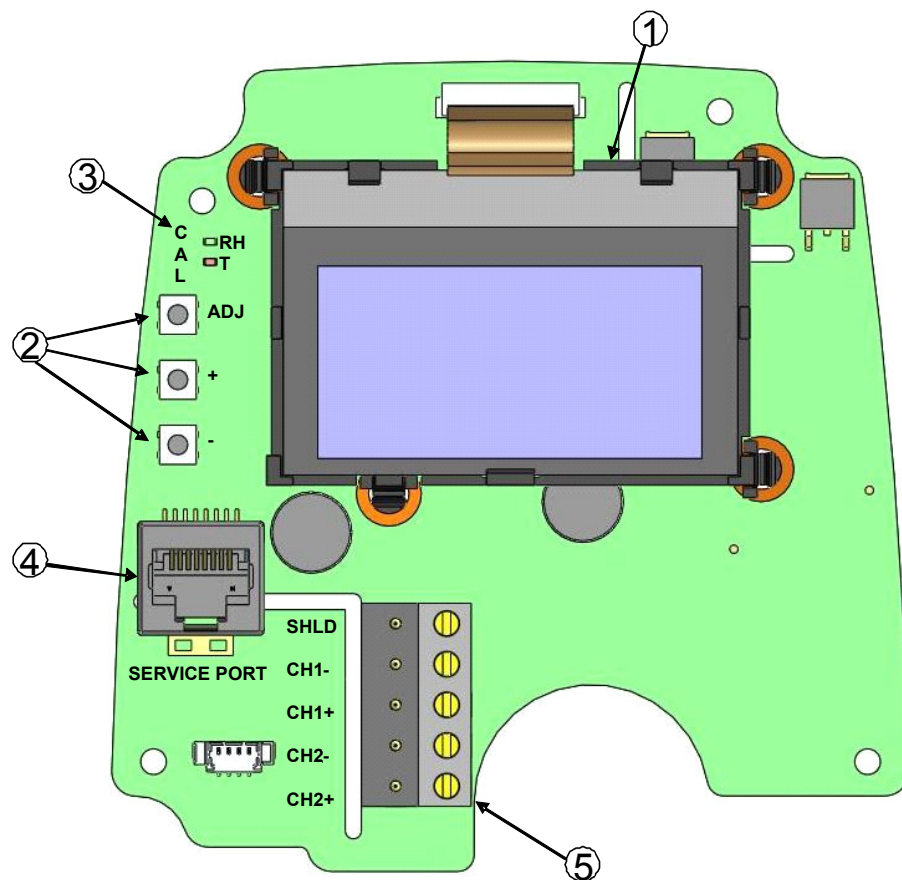

1011-151

Figure 11 HMT120 Component Board

The following numbers refer to Figure 11 above:

- 1 = Optional LCD display
- 2 = Adjustment buttons
- 3 = Indicator LEDs
- 4 = Service port
- 5 = Field wire terminals

1. Remove the transmitter cover. See section Opening the Transmitter Cover on page 13.
2. Insert the signal wires through the selected cable gland/conduit fitting in the bottom of the transmitter or alternatively through the rubber grommet at the back side of the transmitter.
3. Connect the wires as indicated in Figure 12 and in Table 3 on page 22. Suitable wire size is between 0.5 mm^2 and 1.5 mm^2 .

NOTE If an isolated output is required with current outputs, both channels require their own power supply. CH1 is always required to be powered because CH1 is the main output, and the transmitter will not operate if only CH2 is connected.

4. Close the cover by keeping it slightly tilted and first attaching it to the fixing snaps at the top of the enclosure base and then pushing the lower part of the cover firmly forward until it locks. The transmitter is ready for use.

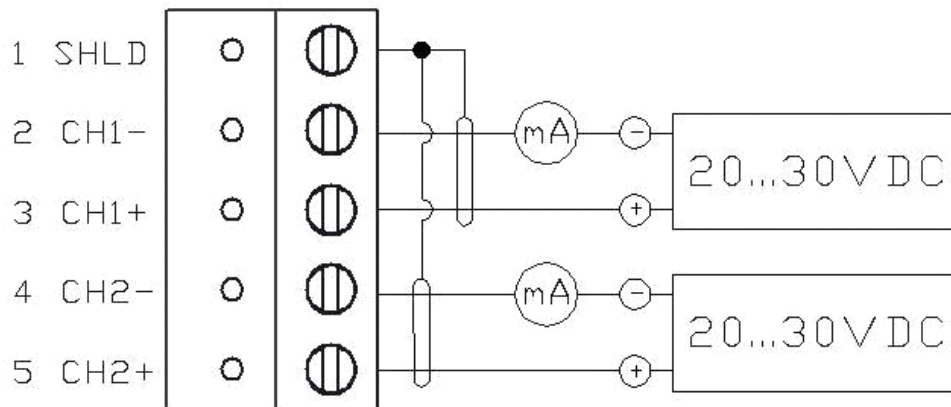

1011-152

Figure 12 Isolated Current-Loop Wiring

Table 3 Wiring Table

Terminal	Current Output (2-Wire, CH2 Isolated)
1	Cable shield (optional)
2	CH1- (signal and power supply -)
3	CH1+ (signal and power supply +)
4	CH2- (signal and power supply -)
5	CH2+ (signal and power supply +)

The numbers 1 ... 5 in the first column of the wiring table refer to Figure 12 above.

CHAPTER 4

SERVICE PORT

This chapter describes the service port of the HMT120.

Using the Service Port

HMT120 motherboard has an 8-pin RJ-45 connector for service use. Service port uses RS-232 signaling levels. Vaisala offers an optional USB cable (Vaisala order code 219685) for connecting the transmitter to your PC.

NOTE

The service port is intended for short-term use such as calibration. For permanent installation, use the analog output.

Connecting a PC to the service port may cause erroneous analog output because of a possible ground loop. Use the service port for service only and disconnect the PC after the service operation.

The cable can also provide operation power to the transmitter, so the wires at the screw terminals need not to be connected in order to operate the transmitter.

If you have not used the HMT120 USB cable before, install the driver that came with the cable. Refer to section Installing the Driver for the USB Cable below for detailed instructions.

Installing the Driver for the USB Cable

Before taking the USB service cable into use, you must install the provided USB driver on your PC.

1. Check that the USB service cable is not connected. Disconnect the cable if you have already connected it.
2. Insert the media that came with the cable, or download the latest driver from www.vaisala.com.
3. Execute the USB driver installation program (setup.exe), and accept the installation defaults. The installation of the driver may take several minutes.

4. After the driver has been installed, connect the USB service cable to a USB port on your PC. Windows will detect the new device, and use the driver automatically.
5. The installation has reserved a COM port for the cable. Verify the port number, and the status of the cable, using the **Vaisala USB Instrument Finder** program that has been installed in the Windows Start menu.

Windows will recognize each individual cable as a different device, and reserve a new COM port. Remember to use the correct port in the settings of your terminal program.

There is no reason to uninstall the driver for normal use. However, if you wish to remove the driver files and all Vaisala USB cable devices, you can do so by uninstalling the entry for **Vaisala USB Instrument Driver** from the **Programs and Features** menu in the Windows Control Panel. In Windows XP and earlier Windows versions the menu is called **Add or Remove Programs**.

Terminal Application Settings

The default settings of the HMT120 serial interface are presented in Table 4.

Table 4 Default Serial Interface Setting

Property	Value
Baud rate	19200
Parity	None
Data bits	8
Stop bits	1
Flow control	None

The steps below describe how to connect to the HMT120 using the PuTTY terminal application for Windows (available for download at www.vaisala.com) and a USB serial interface cable:

1. Connect the USB cable between your PC and the service port of the HMT120.
2. Start the PuTTY application.
3. Select the **Serial** settings category, and check that the correct COM port is selected in the **Serial line to connect to** field.

NOTE

You can check which port the USB cable is using with the **Vaisala USB Instrument Finder program** that has been installed in the Windows Start menu.

4. Check that the other serial settings are correct for your connection, and change if necessary. **Flow control** should be set to **None** unless you have a reason to change it.
5. Click the **Open** button to open the connection window and start using the serial line.

NOTE

If PuTTY is unable to open the serial port you selected, it will show you an error message instead. If this happens, restart PuTTY and check the settings.

6. You may need to adjust the **Local echo** setting in the **Terminal** category to see what you are typing on the serial line. To access the configuration screen while a session is running, click the right mouse button over the session window, and select **Change Settings...** from the pop-up menu.

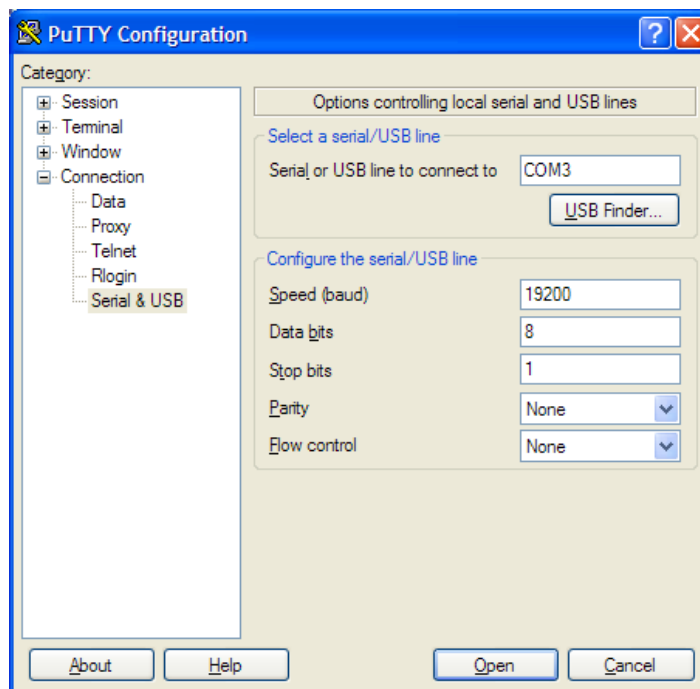

0807-004

Figure 13 PuTTY Terminal Application

List of Serial Commands

All commands can be issued either in uppercase or lowercase.

The notation <cr> refers to pressing the carriage return (ENTER) key on your computer keyboard. Enter a <cr> to clear the command buffer before starting to enter commands.

Whenever you change any of the parameters and want to store the changes permanently, use the **SAVE** command.

Table 5 Serial Port Commands

Command	Description
?	Show transmitter information
ACAL	Calibrate analog outputs
AERR	Set/show analog output error levels
AOUT	Show analog output status
ASEL	Set/show analog output quantities and scaling
ATEST	Test analog outputs
CALCS	Set/show measured quantities
CDATE	Set/show calibration date
CRH	Calibrate probe RH
CRHCLR	Restore probe RH factory calibration
CT	Calibrate probe T
CTCLR	Restore probe T factory calibration
CTEXT	Set/show calibration info
DSEL	Set/show displayed quantities
ECHO	Set/show terminal echo mode
ENV	Set/show environmental parameters
ERRS	Display active errors
FORM	Set/show output formatting
FRESTORE	Restore all transmitter settings to factory defaults
HELP	List available commands
INTV	Set/show the continuous output interval
R	Start continuous outputting
RESET	Reset transmitter
RESTORE	Restores the latest saved settings
S	Stop continuous outputting
SAVE	Save changed settings to FLASH memory
SEND	Output the reading once
SERI	Set/show Service Port settings (Default: 19200 N 8 1)
SMODE	Set the serial interface mode
SYSTEM	Show transmitter information and build date
UNIT	Set/show output unit
VERS	Show firmware version of the transmitter

Device Information and Status

Show Device Information

The ? command outputs a listing of device information.

?<cr>

Example:

```
>?
Device Name       : HMT120
SW Name           : HMT120/130
SW model          : HMT120
SW version        : 0.9.3.389
Serial number     : "F2220101"
Unit              : METRIC
Ch1 Status        : ON
Ch2 Status        : ON
Probe name        : "HMP110"
Probe SW          : "1.01.1"
Probe SW date     : ""
Probe SN          : "F0740011"
>
```

Set/Show Available Quantities

The **CALCS** command shows the abbreviations of the quantities measured by HMT120. The command can also be used to select the desired quantities for measurement. Only after the quantities have been set with the **CALCS** command, can these quantities be selected for different outputs (see commands **DSEL**, **ASEL**, and **FORM**). The quantities in **DSEL**, **ASEL**, and **FORM** must match with **CALCS**.

CALCS [*q1 q2*]<cr>

where

q1, q2 = Any two of the allowed quantity parameters, i.e. RH, T, TD, TDF, A, X, H, TW, PWS, PW

Examples:

```
>calcs
RH Td
>

calcs td t
>
```

NOTE

Single-parameter transmitters HMT120H and HMT120T have only one quantity (T for HMT120T, and RH, TD, TDF, A, X, H, TW, PWS, PW for HMT120H.)

Set/Show Calibration Date

Use the **CDATE** command to show or set the calibration date field. (Calibration refers to the calibration of the HMT120's analog outputs.)

CDATE [*date*]<cr>

where

date = Calibration date in format yyyy-mm-dd

Examples:

```
>cdate
Calibrated          : "NOT SET"
>

>cdate 2009-06-22
Calibrated          : "2009-06-22"
>
```

Set/Show Calibration Information

Use the **CTEXT** command to show or set the calibration info field.
(Calibration refers to the calibration of the HMT120's analog outputs.)

CTEXT [*location*]<cr>

where

location = Freely defined text string typically indicating the
calibration location

Examples:

```
>ctext
Calib. info: "VAISALA HELSINKI"
>

>ctext "Calibration lab 2"
Calib. info: "Calibration lab 2"
>
```

Show Analog Output Status

The **AOUT** command shows the following information:

- **Analog out mode** is the output mode for the channel, for example 0 ... 10 V.
- **Error level** is the level that the analog output is set to in case of transmitter error.
- **Status** indicates the current status of the channel. The statuses are
 - **ON**: Normal measurement operation.
 - **OFF**: No quantity selected for the channel using the **ASEL** command. See section Set/show Analog Output Quantity and Scaling on page 38.
 - **ERROR**: Transmitter error, channel set to error level.
 - **TEST**: Analog channel being tested using the **ATEST** command. See section Test Analog Outputs on page 40.

AOUT<cr>

Example:

```
>aout
*** ANALOG OUTPUT 1 ***
Ch1 Analog out mode : 4_20MA
Ch1 Notification    : ON
Ch1 Error level     : 3.6
Ch1 Status          : ON
Ch1 Quantity        : RH
RH lo                : 0
RH hi                : 100
RH                  : 23.32 %
Current              : 7.73 mA

*** ANALOG OUTPUT 2 ***
Ch2 Analog out mode : 4_20MA
Ch2 Notification    : ON
Ch2 Error level     : 3.6
Ch2 Status          : ON
Ch2 Quantity        : T
T lo                : -60
T hi                : 100
T                   : 23.66 'C
Current              : 12.37 mA
>
```

Show System Information

SYSTEM<cr>

Example:

```
>system
Device Name       : HMT120
SW Name           : HMT120/130
SW model          : HMT120
SW version        : 1.0.0.500
Serial number     : A1234567
>
```

Show Firmware Version

VERS<cr>

Example:

```
>vers
HMT120 / 0.1.0.103
>
```

Serial Line Output Commands

Start Continuous Outputting

Use the **R** command to start the continuous outputting of measurement values as an ASCII text string to the serial line. The output always includes the readings of the currently selected analog output quantities.

R [X]<cr>

Example:

```
>r
RH= 25.10% T= 24.77'C
RH= 25.12% T= 24.96'C
...
```

Outputting the results continues in intervals issued with the command **INTV**. You can stop the output by entering the **S** command.

Output data formatting can be defined with **FORM** command. With **X** parameter the transmitter will output RH + T value in predefined format regardless of what quantities are selected.

Stop Continuous Outputting

Use the **S** command to stop the continuous measurement output:

```
S<cr>
```

Set/show Output Interval

Use the **INTV** command to show or set the output interval of the serial line measurement messages (applies when **R** command or RUN mode is used). The shortest output interval is one second. This command has no effect on the operation of the analog outputs.

```
INTV [n xxx]<cr>
```

where

n = Time interval in range 1 ... 255
xxx = Time unit = "S", "MIN", or "H"

Examples:

```
>intv
Value          : 1
Unit           : S
>
```

```
>intv 3 min
Value          : 3
Unit           : MIN
>
```

Output a Reading Once

Use the **SEND** command to output a single measurement reading from the transmitter.

```
SEND [X]<cr>
```

Example:

```
>send
RH= 25.12 % T= 24.91 'C
>
```

With X parameter the transmitter will output RH + T value in predefined format regardless of what quantities are selected.

Calibration Commands

Serial commands that are related to calibration are described below. For the actual calibration procedures, see section Calibration and Adjustment on page 50.

Calibrate Humidity Measurement

Use the **CRH** command to perform a one-point or two-point humidity (RH) calibration.

CRH<cr>

When performing a one-point calibration, you need to place the probe in a single humidity reference with RH < 50%. Run the command and enter the exact RH of the reference after the measurement has stabilized. Exit the command by pressing the ESC key before proceeding to the second point (see example below). To update the value, press ENTER without inputting a value.

For two-point calibration, the first point requires a RH < 35% humidity reference, the second point must be RH > 50%.

Example 1: One-point calibration

```
>crh
RH:      11.29915720 Ref1 ? 11.3
Press ENTER to continue or ESC to exit
OK
>
```

Example 2: Two-point calibration

```
>crh
RH:      11.29915720 Ref1 ? 11.3
Press ENTER to continue or ESC to exit
RH:      75.04306440 Ref2 ? 75
OK
>
```

Example 3: No calibration, only updating the value

```
>crh
RH:      20.28000200 Ref1 ?
RH:      20.14000000 Ref1 ?
Calibration terminated with ESC
>
```

Restore Probe RH Factory Calibration

Use the **CRHCLR** to restore the probe RH factory calibration.

CRHCLR<cr>

Example:

```
>crhclr
OK
>
```

Calibrate Temperature Measurement

Use the **CT** command to perform a one-point or two-point temperature (T) calibration.

CT<cr>

When performing a one-point calibration, you need to place the probe in a single temperature reference. Run the command and enter the exact temperature of the reference after the measurement has stabilized. Exit the command by pressing the ESC key before proceeding to the second point. To update the value, press ENTER without inputting a value.

For two-point calibration, the second reference point must be at least 20 °C warmer than the first. The measurement reading for the second point will appear when this requirement is met.

Example 1: One-point calibration

```
>ct
T 21.9827 Ref1 ? 22
Press ENTER to continue or ESC to exit
OK
>
```

Example 2: Two-point calibration

```
>ct
T 22.0007 Ref1 ? 22
Press ENTER to continue or ESC to exit
T 44.9847 Ref2 ? 45
OK
>
```

Example 3: No calibration, only updating the value

```
>ct
T 22.0007 Ref1 ?
T 22.0145 Ref1 ?
Calibration terminated with ESC
>
```

Restore Probe T Factory Calibration

Use the **CTCLR** to restore the probe T factory calibration.

CTCLR<cr>

Example:

```
>ctclr
OK
>
```

Calibrate Analog Output

Use the **ACAL** command to calibrate the analog current loop outputs.

ACAL<cr>

After you give this command, the CH1 analog output of the transmitter is set to the low limit (4mA). Measure the output and enter the measured value. After entering the low limit, you must measure and enter the high limit (20mA) also. The same procedure is then repeated with CH2.

Calculated coefficients are printed after the measured values are given.

Example:

```
>acal
Ch1 I1 (mA) ? 5.60
Ch1 I2 (mA) ? 18.40
-1.40562890E+03 a0
1.41171900E+03 a1
OK
Ch2 I1 (mA) ? 5.60
Ch2 I2 (mA) ? 18.40
-1.40562890E+03 a0
1.41171900E+03 a1
OK
>
```

NOTE

Question mark is displayed after certain stabilization time has expired. Values should be entered only after question mark is displayed. Values entered before question mark will be discarded.

Configuring Serial Line Operation

Set/Show Serial Line Settings

Use the **SERI** command to show or set the serial line settings. Use the **SAVE** command after changing the settings to store them. The new settings will be taken into use when the transmitter is reset or powered up.

SERI [*b p d s*]<cr>

where

b = baud rate (9600, 19200, 38400, 76800, 115200)
p = parity (n = none, e = even, o = odd)
d = data bits (7 or 8)
s = stop bits (1 or 2)

Examples:

```
>seri
Baud P D S      : 19200 N 8 1
>
```

```
>seri 9600 e 7 1
Baud rate      : 9600
Parity         : E
Data bits      : 7
Stop bits      : 1
>save
Saving settings...done
>
```

Set/Show Terminal Echo

To show or set the terminal echo status, use the **ECHO** command.

ECHO [ON/OFF]<cr>

Examples:

```
>echo
COM1 Echo      : OFF
>
```

```
>echo on
COM1 Echo      : ON
>
```

Set/Show Serial Interface Mode

Use the **SMODE** command to show or set the serial interface mode. Note that a separate **SAVE** command is not needed to store the new serial interface mode setting.

```
SMODE [STOP/RUN]<cr>
```

In STOP mode: outputting only when command is issued, any command can be used.

In RUN mode: outputting automatically, only command **S** can be used.

Example:

```
>smode stop
Output mode      : STOP
>
```

Configuring Measurement Parameters

Set/Show Environmental Parameters

Use the **ENV** command to show or set the environmental compensation values. In HMT120, the humidity measurement can be compensated for ambient pressure. The value set using **ENV** command is a permanent value which will survive a restart.

```
ENV [x.xxxx]<cr>
```

where

$x.xxxx$ = Absolute pressure in the measuring environment.
The default is **1.013**. The pressure unit is bar.

Example:

```
>env
Pressure (bar)   : 1.013
>

>env 0.980
Pressure (bar)   : 0.98
>save
Saving settings...done
>
```

NOTE

You can use the Vaisala Humidity Calculator to simulate the effect of pressure change to dewpoint. The Humidity Calculator can be found at:

www.vaisala.com/humiditycalculator

Configuring Analog Output

Set/show Analog Output Error Levels

Use the **AERR** command to show or set the analog output error levels.

```
AERR [level1 level2]<cr>
```

where

level1 level2 = Error levels for analog output channel

Examples:

```
>aerr  
Ch1 Error level      : 3.6  
Ch2 Error level      : 3.6  
>
```

```
>aerr 3.85 3.86  
Ch1 Error level      : 3.85  
Ch2 Error level      : 3.86  
>
```

Set/show Analog Output Quantity and Scaling

After you have defined the quantities with the **CALCS** command, use the **ASEL** command to show or set the quantity output by the analog channels, and the scaling that is used. If you do not enter scaling limits, default values are used. Valid quantities are: RH, T, TD, TDF, A, X, H, TW, PWS, PW and NONE. NONE parameter disables analog output and output is forced to error level.

```
ASEL [q1 q2] [lo1 hi1 lo2 hi2]<cr>
```

where

q1 q2 = Analog output channel quantities
lo1 lo2 = Low limits of scaling
hi1 hi2 = High limits of scaling

Syntax for single-parameter transmitters:

```
ASEL [q] [lo hi]<cr>
```

where

q = Analog output channel quantity
lo = Low limit of scaling
hi = High limit of scaling

Examples:

```
>asel
Ch1 Quantity      : RH
RH lo             : 0
RH hi             : 100
Ch2 Quantity      : T
T lo              : -60
T hi              : 100
>
```

```
>asel rh td
Ch1 Quantity      : RH
RH lo             : 0
RH hi             : 100
Ch2 Quantity      : TD
Td lo             : -40
Td hi             : 60
>
```

```
>asel t td 0 60 -20 60
Ch1 Quantity      : T
T lo              : 0
T hi              : 60
Ch2 Quantity      : TD
Td lo             : -20
Td hi             : 60
>
```

```
>asel rh none
Ch1 Quantity      : RH
RH lo             : 0
RH hi             : 100
Ch2 Quantity      : NONE
>
```

```
>asel none none
Ch1 Quantity      : NONE
Ch2 Quantity      : NONE
>
```

Test Analog Outputs

Use the **ATEST** command to test the analog outputs. The **ATEST** command will force the output to the given value, which can then be measured with a calibrated multimeter.

ATEST command affects only the analog outputs and hence it does not disable measurement functions. **ATEST** without parameters will exit the test mode and let the measurement continue. It will also indicate the the current analog output levels in normal measurement state.

ATEST [*val1 val2*]
<cr>

where

val1 val2 = Analog channel output value (mA)

Examples:

```
>atest  
CH1: 3.800000  
CH2: 3.800000  
>
```

```
>atest 3.9 3.9  
CH1: 3.900000  
CH2: 3.900000  
>
```

Other Commands

Set/show Displayed Quantities

After you have defined the quantities with the **CALCS** command, use the **DSEL** command to show or set the displayed quantities. Number of parameters determine the display mode (ie. one or two rows). If one quantity is given, display will switch to one row mode. If two quantities are given, two-row mode is used. Valid quantities are: RH, T, TD, TDF, A, X, H, TW, PWS, and PW.

```
DSEL [q1 q2]<cr>
```

where

Q1 q2 = Quantities to be shown on transmitter display

Syntax for single-parameter transmitters:

```
DSEL [q]<cr>
```

where

Q = Quantity to be shown on transmitter display

Examples:

```
>dsel
1. quantity      : RH
2. quantity      : T
>
```

```
>dsel rh t
1. quantity      : RH
2. quantity      : T
>
```

```
>dsel t
1. quantity      : T
>
```

Set/show Output Formatting

After you have defined the quantities with the **CALCS** command, use the **FORM** command to set the output format for **SEND** and **R** commands.

FORM<*format*>

where

format = A formatting string, which can consist of following fields:

“”	String constant
x.y	Value length modifier. x is numbers before dot and y is numbers after dot.
Ux	Unit field length. U...U format is also supported.
Q	Quantity name (e.g. rh, t, td etc.)
#t or \t	Tabulator
#r or \r	Carriage return
#n or \n	Line feed (new line)

Note 1. Quantity must be after x.y and Ux modifiers.

Note 2. There must be a space between parameters, #r#n or \r\n is not supported.

Note 3. Max. string length is 80 characters.

Note 4. If Ux parameter is not used, unit is not displayed.

Examples:

```
>form "RH= " 3.2 U2 rh #r #n
>send
RH= 32.16 %
>
```

```
>form "t=" 4.1 U3 t \t "rh=" 3.2 U2 rh \r \n
>send
t= 22.5 'C      rh= 29.12 %
>
```

```
>form "t=" 4.1 U3 t \t "rh=" rh \r \n
>send
t= 22.3 'C      rh= 29.5 %
>
```

```
>form 3.2 UUU "RH=" rh \t "T=" t \r \n
>send
RH= 27.99 %    T= 23.34 'C
>
```

```
>form 3.3 rh " " t \r \n
>send
26.740 23.660
>
```

```
>form "->" "RH=" 3.2 U2 rh " " "T=" 3.1 U3 t #r #n
>send
->RH= 27.79 % T= 23.4 'C
>
```

Display Command List

Use the **HELP** command to display a list of available commands.

```
HELP<cr>
```

Display Active Errors

Use the **ERRS** command to display the currently active error codes. For troubleshooting active errors, see **Table 7** on page 67.

```
ERRS<cr>
```

Example (no active errors):

```
>errs  
No errors.  
>
```

Save Changed Settings

Use the **SAVE** command to save changed settings to the transmitter FLASH memory. Most settings have to be saved or the changes are lost at the next reset or power down.

NOTE

The **SMODE** command saves the new serial mode immediately; a separate **SAVE** command is not needed.

The probe calibration commands (**CRH**, **CT**, **CRHCLR**, **CTCLR**) store the parameters into the probe's memory automatically without a separate **SAVE** command.

```
SAVE<cr>
```

Example:

```
>save  
Saving settings...done  
>
```

Restore Saved Settings

Use the **RESTORE** command to restore saved settings from transmitter FLASH memory to RAM. All unsaved changes will be lost.

RESTORE<cr>

Example:

```
>restore
Restoring default settings...done
>
```

Reset Transmitter

Use the **RESET** command to reset the transmitter. Upon reset or power-up, the transmitter enters the serial mode that has been set with the **SMODE** command.

After reset the configuration is loaded from FLASH memory. That configuration can be altered with **SAVE**-command.

RESET<cr>

Example (transmitter set to serial mode STOP, will output transmitter software version at reset):

```
>reset
HMT120 / 0.1.0.001
Type "help" for command list
>
```

Restore Factory Settings

Use the **FRESTORE** command to restore the factory settings to the transmitter. All user settings, including the user-performed calibration corrections, will be lost. The transmitter will revert back to the factory calibrated settings. Note that this only returns the factory settings of the transmitter and not of the interchangeable probe (see section Restore Probe RH Factory Calibration on page 34 and section Restore Probe T Factory Calibration on page 35).

FRESTORE<cr>

Example:

```
>frestore
Restoring factory defaults...done
>
```

Set/show Output Unit

Use the **UNIT** command for output unit selection (metric or non-metric).

UNIT [METRIC/NON_METRIC]<cr>

Example:

```
>unit
Unit                : METRIC
>

>unit non_metric
Unit                : NON_METRIC
>
```

This page intentionally left blank.

CHAPTER 5

MAINTENANCE

This chapter provides information that is needed in basic maintenance of HMT120.

Replacing the HUMICAP[®] Sensor

Fixed and Remote Probe Models

1. Remove the filter (plastic grid or sintered stainless steel).
2. Remove the damaged sensor and insert a new one.
3. Recalibrate the probe.
4. Replace a dirty filter to ensure a maximum lifetime and a fast response for the sensor. Do not attempt to clean the filter.

Removing and Fastening the Probe

Fixed Probe Model

Remove and replace the probe as follows:

1. Loosen the metal locking bushing by carefully turning it counter clockwise.
2. Remove the probe from the transmitter by pulling it gently downwards.
3. Attach the new probe to the four pin M8 panel connector at the transmitter (only one position possible).
4. Tighten the locking bushing to the M8 panel connector by turning it clockwise.

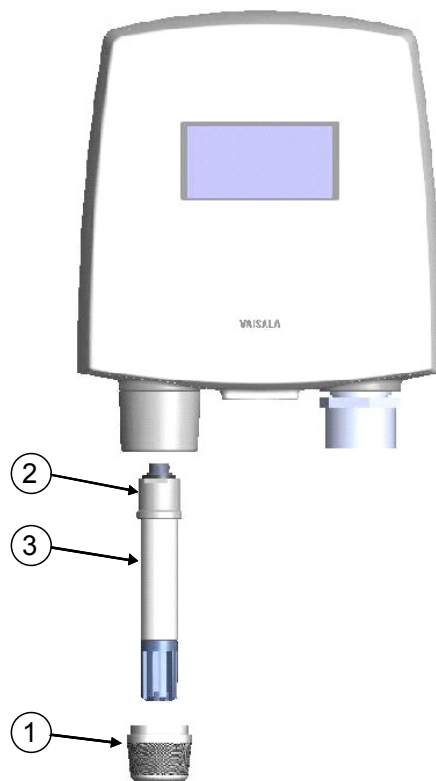

1011-153

Figure 14 Removing the Humidity Probe (Fixed Probe Model)

The following numbers refer to Figure 14 above:

- 1 = Locking bushing
- 2 = Holder bushing (attached permanently to the probe)
- 3 = HMP110 probe

Remote Probe Model

1. Unscrew the small sleeve that secures the probe in place at the end of the probe cable and pull out the probe.
2. Replace the probe and screw the small sleeve back on, securing the probe tightly in place.

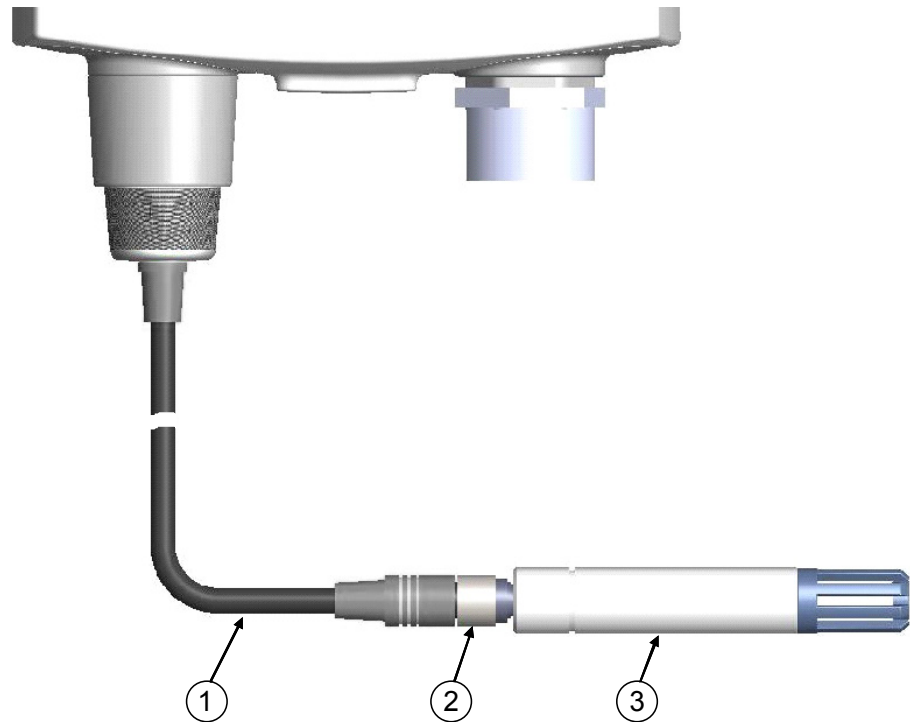

1011-154

Figure 15 Removing the Humidity Probe (Remote Probe Model)

The following numbers refer to Figure 15 above:

- 1 = Probe cable
- 2 = Sleeve securing the probe to the cable
- 3 = HMP110 probe

Calibration and Adjustment

Calibrate and adjust the HMT120 using the push-buttons on the motherboard, serial line commands (see section Calibration Commands on page 33), or with portable humidity meters HM70 or HMI41.

A calibrator kit is needed for calibration against saturated salt solutions. The HMK15 Humidity Calibrator and pre-measured certified salts are available from Vaisala. For further information, please contact your Vaisala representative.

Vaisala Service Centers also offer accredited calibrations for humidity and temperature. See contact information on page 69.

It is also possible to remove the HMP110 probe and replace it with a new one. The old probe can be adjusted using another HMT120 transmitter body, if you have one available.

NOTE

RH Field Calibration and Adjustment, as instructed in the following pages, is restricted to a certain adjustment range to minimize the effects of special circumstances, such as chemical contamination. In case the probe is outside its adjustment/trim range due to, for example, chemical exposure, the calibration cannot be completed. In this case, it is recommended that you change the probe or contact Vaisala Services.

HMT120 Push-Button Calibration

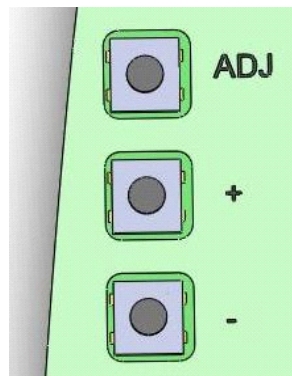

1011-155

Figure 16 Adjustment Buttons

Calibration and adjustment of the HMT120 can be done by using the adjustment buttons found at the transmitter. The two-point humidity adjustment is carried out by using two relative humidity references: for example saturated salt points 11 %RH (LiCl) and 75 %RH (NaCl). The difference between the two humidity reference points must be at least

30 %RH. The difference between the two temperature reference points must be at least 30 °C.

NOTE

In push-button calibration, the transmitter outputs are by default relative humidity in the range 0...100% RH in CH1 and temperature in the range -40 ... +80 °C in CH2 regardless what the actual transmitter settings are. Outputs mean in this case both the display and analog current outputs.

Humidity and Temperature Adjustment

To make a humidity or temperature adjustment (the same instructions apply to both one-point and two-point calibration):

1. Open the transmitter cover and you can see three buttons marked **ADJ**, + and -. There are also two indicator LEDs, one green and one red on the HMT120 motherboard.
2. Press the **ADJ** button and hold it down until the green indicator LED begins to blink slowly (800ms cycle time).
3. HMT120 transmitter is now in RH calibration state. Analog output and optional display will still follow the actual measured RH value.

NOTE

If you do not wish to perform the RH adjustment at this time, press **ADJ** button one more time. The green indicator LED turns off and the red indicator LED begins to blink slowly (800ms cycle time) to indicate T calibration state. Now you can continue following the instructions from step 7 onward.

4. Remove the filter and insert the probe into a measurement hole of the dry end reference chamber (for example, LiCl: 11 %RH) to do the low humidity offset adjustment.

NOTE

Do not touch the adjustment buttons before the conditions have stabilized. This takes approximately 30 minutes.

5. Press either the - or + button at least once, make sure that the I_{out} current is correct, adjust using the - and + buttons if needed, and press the **ADJ** button again. The green indicator LED begins to blink faster (400ms cycle time).

NOTE

If you do not wish to perform the two-point RH adjustment at this time, press the **ADJ** button one more time. The green indicator LED turns off and the red indicator LED begins to blink slowly (800ms cycle time) to indicate T calibration state. Now you can continue following the instructions from step 7 onwards.

If one-point calibration is done at more than 50 %RH, a gain adjustment is done instead of an offset adjustment.

6. Insert the probe into the high end reference chamber (for example, NaCl: 75 %RH chamber in the humidity calibrator HMK15) and do the high humidity gain adjustment by using the - and + buttons to make sure the I_{out} current is correct (you have to press either - or + at least once even if the value is correct). To finish the RH calibration, press the **ADJ** button. The green LED is now turned off and the red indicator LED begins to blink slowly (800ms cycle time).
7. HMT120 transmitter is now in T calibration state. Analog output and optional display will still follow the actual measured T value.

NOTE

If you do not wish to perform the T adjustment at this time, press **ADJ** button one more time. The red indicator LED is turned off and the transmitter returns to normal mode. The calibration procedure is now finished.

8. Insert the probe into a known reference temperature (if HMK15 Humidity Calibrator is not used) and let the temperature reading stabilize.

NOTE

Do not touch the adjustment buttons before the conditions have stabilized.

9. Using the - and + buttons, make the temperature offset adjustment by making sure the I_{out} current is correct (you have to press either - or + at least once even if the value is correct) and press the **ADJ** button. The red indicator LED begins to blink faster (400ms cycle time).

NOTE

If you do not wish to perform the two-point T adjustment at this time, press the **ADJ** button one more time. The red indicator LED is turned off and the transmitter returns to normal mode. The calibration procedure is now finished.

10. Insert the probe into another reference temperature.

NOTE

Do not touch the adjustment buttons before the conditions have stabilized.

11. Using the - and + buttons, make the temperature gain adjustment by making sure the I_{out} current is correct (you have to press either - or + at least once even if the value is correct).
12. Press the **ADJ** button one more time. The red indicator LED turns off and the transmitter returns to normal mode. The calibration procedure is now finished.

NOTE

In case of calibration error, both LEDs blink alternately at a very fast rate (cycle time 200ms) for a period of 2s after which the transmitter returns to normal mode.

NOTE

In case of using a HMT120 transmitter with display option, the following texts are shown at the display during calibration:

- "**Probe cal: RH 1**" corresponding the green LED blinking slowly
- "**Probe cal: RH 2**" corresponding the green LED blinking fast
- "**Probe cal: T 1**" corresponding the red LED blinking slowly
- "**Probe cal: T 2**" corresponding the red LED blinking fast
- "**Probe cal: Error**" corresponding both LEDs blinking alternately at very fast rate

Adjustment with HM70

You can check and adjust the HMT120 relative humidity measurement with the HM70 Hand-Held Humidity and Temperature meter. A HM70-connection cable is needed. Vaisala order code: 211339.

There are four types of adjustments available: field checking and adjustment using a calibrated reference probe, one-point adjustment using a calibrator, two-point adjustment using a calibrator, and LiCl-NaCl adjustment.

Follow the first seven steps and continue according to the chosen adjustment method.



0505-351

Figure 17 Location of the MI70 Probe and Cable Connector Ports

1. Connect the 211339 HM70-connection cable to the **SERVICE PORT** connector on the HMT120 motherboard (see Figure 11 on page 21).
2. Connect the other end of the connection cable to either of the HM70's connector ports located on the bottom of the indicator (see Figure 17 above).
3. Turn on both devices (or just HM70, in case that HMT120 is on continuously).
4. Check that the transmitter reading is shown on the indicator. The reading of the transmitter is shown on the top or middle row of the display, depending on which connector port the connection cable is connected to.
5. Press the **ADJ** button on the HMT120 motherboard to open the adjustment mode. Both LEDs on HMT120 motherboard remain in OFF state and text "**Starting adjustment mode for HMP110**" is shown at the MI70 display.

NOTE

In case of using a HMT120 transmitter with display option, text "**MI70 adjustment mode**" is shown on the upper row of HMT120 display.

NOTE

From this point onward, the local adjustment buttons at HMT120 are disabled and adjustment is carried out using the MI70 indicator. HMT120 display and analog outputs will always follow the actual measured RH/T value when in MI70 adjustment mode. When operating the MI70, do not press the buttons too quickly or the calibration may fail. Wait for one second between each press.

6. Press **OK** to start adjustment.
7. Check the environment settings if needed. Otherwise, press **NO**. Select **RH** or **T adjustment**. Continue according to the directions of the desired adjustment method.

Field Checking and Adjustment Using a Calibrated Reference Probe

Follow steps 1 to 7 on page 54 and continue as follows:

8. Check that the probes are located in equal conditions and wait until the readings have stabilized. This may take 30 minutes or more. If you are close to the probes, do not breath in their direction.
9. Press **ADJUST** to continue adjusting.
10. Choose **To same as RH_{I/II}** from the MI70 adjustment menu, press **SELECT** (MI70 automatically recognizes which port the HMP70 series probe is connected to).
11. Confirm the adjustment by pressing **YES**.
12. The adjustment is done. Press **BACK** and **EXIT** to return to the basic display.
13. Turn off the MI70 and detach the connection cable.

One-Point Adjustment Using a Calibrator

When adjusting the transmitter in only one reference condition, please take care that the reference condition represents the measuring environment. MI70 indicator is used now only as a terminal for visualizing and setting the transmitter's RH reading.

Follow steps 1 to 7 on page 54 and continue as follows:

8. Remove the filter from the transmitter's probe and insert the probe head into the reference condition.
9. Press **ADJUST** to continue adjusting.
10. Choose **1-point adjustment** from the MI70 adjustment menu and press **SELECT**.

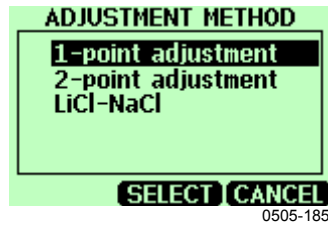

Figure 18 Example of the MI70 Adjustment Menu

11. Press **READY** when the reading has stabilized in the reference condition. This may take 30 minutes or more. You can follow the stabilization from the **GRAPH** display.

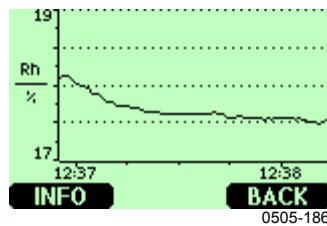

Figure 19 Example of the MI70 Adjustment Mode Graph Display

12. Enter the correct reference value with the arrow buttons. Press **OK**.
13. Confirm the adjustment by pressing **YES**.
14. The adjustment is done. Press **BACK** and **EXIT** to return to the basic display.
15. Turn off the MI70 and detach the connection cable.

Two-Point Adjustment Using a Calibrator

Note that the difference between the two reference humidities must be at least 50 %. MI70 indicator is used now only as a terminal for visualizing and setting the transmitter's RH reading.

Follow steps 1 to 7 on page 54 and continue as follows:

8. Remove the filter from the transmitter's probe and insert the probe head into the lower humidity reference condition.
9. Press **ADJUST** to continue adjusting.
10. Choose **2-point adjustment** from the MI70 adjustment menu and press **SELECT**.
11. Press **READY** when the reading has stabilized in the first reference condition (may take 30 minutes or more). You can follow the stabilization from the **GRAPH** display.
12. Enter the correct reference value in the first condition with the arrow buttons. Press **OK**.

13. Remove the probe from the first reference condition and insert the probe head into the higher humidity reference condition.
14. Press **READY** when the reading has stabilized in the second reference condition (may take 30 minutes or more). You can follow the stabilization from the **GRAPH** display.
15. Enter the correct reference value in the second condition with the arrow buttons. Press **OK**.
16. Confirm the adjustment by pressing **YES** (by pressing **NO** you return to adjustment mode display and no changes are made). If the difference between the two reference conditions is less than 50 %RH, adjustment cannot be done.
17. The adjustment is done. Press **BACK** and **EXIT** to return to the basic display.
18. Turn off the MI70 and detach the connection cable.

LiCl-NaCl Adjustment

This adjustment is done using relative humidity references 11.3 %RH (LiCl) and 75.5 %RH (NaCl).

Follow steps 1 to 7 on page 54 and continue as follows:

8. Remove the filter from the transmitter's probe and insert the probe head into the LiCl salt chamber.
9. Press **ADJUST** to continue adjusting.
10. Choose **LiCl-NaCl autom.** from the MI70 adjustment menu and press **SELECT**. Press **OK** to accept the note telling about references.
11. Press **READY** when the reading has stabilized in the LiCl salt chamber (may take 30 minutes or more). You can follow the stabilization from the **GRAPH** display.
12. Remove the probe from the LiCl salt chamber and insert the probe head into the NaCl salt chamber.
13. Press **READY** when the reading has stabilized in the NaCl salt chamber (may take 30 minutes or more). You can follow the stabilization from the **GRAPH** display.
14. Confirm the adjustment by pressing **YES** (by pressing **NO** you return to adjustment mode display and no changes are made).
15. The adjustment is done. Press **BACK** and **EXIT** to return to the basic display.
16. Turn off the MI70 and detach the connection cable.

Temperature Field Check and Adjustment by Using a Calibrated Reference Probe

Follow steps 1 to 7 on page 54 and continue as follows:

8. Check that the probes are located in equal conditions and wait until the readings are stabilized (can take 30 minutes or more). If you are close to the probes, do not breathe in their direction.
9. Press **ADJUST** to continue adjusting.
10. Press **To same as T_{II/I}**, press **SELECT**. (MI70 always recognizes the port to which the HMP70 series probe is connected).
11. Confirm by pressing **YES**.

NOTE

If the temperature difference between the reference probe and HMT120 is too large, the adjustment cannot be done (HM70 will notify you of this). The available reserve for T adjustment of HMT120 depends on the initial temperature calibration of the unit.

12. Adjustment is done. Press **BACK** and **EXIT** to return to the basic display.
13. Switch off the MI70 and detach the calibration cable from MI70 and from the transmitter.

Adjustment with HMI41

You can check and adjust the HMT120 relative humidity measurement with the HMI41 indicator and HMP41/45/46 probes. A HMI41-connection cable is needed. Vaisala order code: 25917ZZ.

There are three adjustment modes available: offset (dry point), gain (wet point), and two-point adjustment. All of these can be performed using the HMI41 either as a reference meter (for example when the transmitter is mounted in an air-conditioning channel) or only as a terminal for visualizing and setting the transmitter's RH reading.

Offset and gain adjustments are performed the same way and differ only in internal calculations. Select offset adjustment when the reference humidity is < 65 %RH and gain adjustment when the reference humidity is ≥ 65 %RH. Two-point adjustment is more accurate, and includes both offset and gain corrections. For performing two-point adjustment, you need two separate measurement points with a difference of at least 50 %RH between them.

Follow the general directions of connecting the HMI41 to the HMT120 and selecting the HMI41 calibrator function and then continue according to the chosen adjustment method.

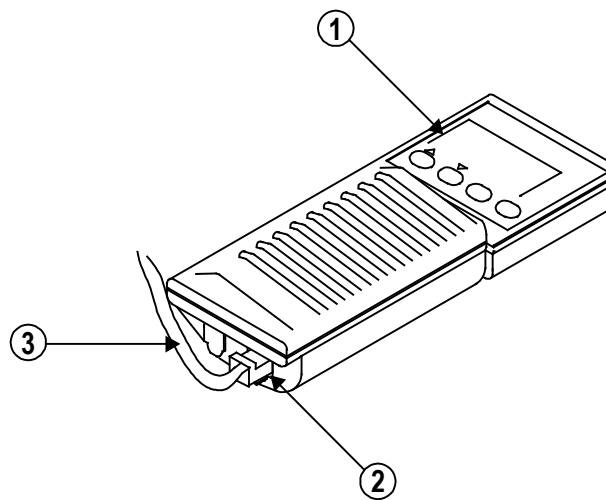

0505-187

Figure 20 Location of the HMI41 Calibration Connector

The following numbers refer to Figure 20 above:

- 1 = HMI41 indicator
- 2 = EXT connector
- 3 = 25917ZZ connection cable

Connections and Selecting the Calibrator Function

1. To select the calibrator function from the HMI41, press the **ON/OFF** button until you can see some text on the display. Then release the **ON/OFF** button and within 1 ... 2 seconds, press both **ENTER** and **MODE** buttons until the following display appears:



2. After a few seconds, the display changes to show the following:

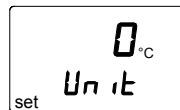

If the basic settings (display units, automatic power off function, display quantities, and pressure) have to be changed, please refer to the HMI41 Operating Manual. Otherwise, press **ENTER** repeatedly until the following display appears:

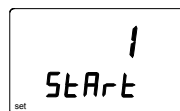

To calibrate the HMT120, select number 3 with buttons ▲ (number up) and ▼ (number down) and then press **ENTER**.

3. Next the baud rate appears on the display. Use the baud rate 19200 (= 19.2 on the HMI41 display) with the HMT120 series. If the baud rate on the HMI41 display is not correct, change it with buttons ▲ and ▼. When the baud rate is correct, press **ENTER**, and the serial communications settings display appears. The correct settings for HMT120 series are: N, 8, 1. If needed, change the settings with buttons ▲ and ▼ until they are correct, press **ENTER**, and then **ON/OFF**.

These settings are stored in the HMI41 memory; when the HMI41 is turned on again, it will automatically wake up as a calibrator for digital transmitters with these serial line settings. After making these settings, continue with the adjustment and follow the directions of the chosen adjustment method.

Offset and Gain Adjustments

Offset and gain adjustments are performed in the same way (they differ only in internal calculations), so this section is valid for both methods.

4. Connect the 25917ZZ HMI41-connection cable to the **SERVICE PORT** connector on the HMT120 motherboard (see Figure 11 on page 21).
5. Connect the other end of the connection cable to the **EXT** connector located on the bottom of the HMI41 indicator (see Figure 20 on page 59).
6. Turn on both devices. Wait until the following display appears:



A rectangular display showing the text "RH CAL" on the top line and "OFFSE" on the bottom line.

7. Select the appropriate adjustment mode with the ▲ and ▼ buttons. Select offset adjustment if the humidity is < 65 %RH and gain adjustment if the humidity is ≥ 65 %RH:



A rectangular display showing the text "RH CAL" on the top line and "OFFSE" on the bottom line.

OR



A rectangular display showing the text "RH CAL" on the top line and "GA IN" on the bottom line.

Press **ENTER** to confirm the selection. A display similar to the following appears:

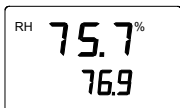

A rectangular display showing the text "RH 75.7%" on the top line and "76.9" on the bottom line.

NOTE

In case of using a HMT120 transmitter with display option, the text "**HMI41 adjustment mode**" is shown at the upper row of HMT120 display.

The next sections describe how to perform offset and gain adjustments in two different ways.

HMI41 as a Reference Meter

The HMI41 humidity probe is used to show the correct humidity value (be sure that the reference probe has previously been adjusted). Connect the cable and select the appropriate adjustment method as previously explained, and continue according to the following instructions.

8. A display similar to the one below should be visible:

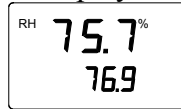

Numbers on the first line indicate the transmitter reading, and the numbers on the second line indicate the reference probe reading.

9. Let the readings stabilize (may take 30 minutes or more). If you prefer, you can change the display to show the difference in the readings. Press **HOLD** and a display similar to the following appears:

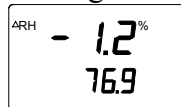

The numbers on the first line indicate how much the transmitter reading differs from that of the HMI41 reference probe. The numbers on the second line indicate the reference probe reading. You can return to the previous display by pressing **HOLD** again.

10. When the readings have stabilized, press **ENTER** to conclude the adjustment. When **ENTER** is pressed, the transmitter reading is corrected to the reference probe reading. If the adjustment has been successful, the following display appears:



11. The data is now stored in the transmitter memory. If the adjustment has not been successful, the following display appears:



In this case, perform the adjustment again. Whether the adjustment was successful or not, the HMI41 always returns to display the selected adjustment mode.

12. After successfully completing the adjustment, turn off the HMI41 and disconnect the cable.

HMI41 as a Terminal

The HMI41 can also be used for visualizing and setting the transmitter's RH reading manually.

8. A display similar to the one below should be visible:

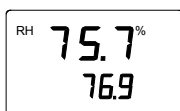

The numbers on the first line indicate the transmitter reading, and the numbers on the second line indicate the HMI41 probe reading.

9. Let the readings stabilize and press **MODE**. The following display appears:

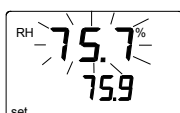

The HMI41 now works only as a terminal for setting the humidity reading. The numbers on the first line are blinking, and the numbers on the second line indicate the transmitter reading.

10. You can now set the blinking reading to the correct value (for example, the equilibrium RH of a salt solution) with the buttons **▲** and **▼**. Press **ENTER** to conclude the adjustment. If the adjustment has been successful, the following display appears:



11. The data is now stored in the transmitter memory. If the adjustment has not been successful, the following display appears:





In this case, perform the adjustment again. Whether the adjustment was successful or not, the HMI41 always returns to display the selected adjustment mode.

12. After successfully completing the adjustment, turn off the HMI41 and disconnect the cable.

Troubleshooting

Table 6 presents a summary of the error messages that may appear during adjustment with the HMI41.

Table 6 Common Problems During Adjustment and Their Remedies

Error Message	Probable Cause	Remedy
	This message may appear, for example, if the difference between the reference humidities is too small (< 50 %RH).	Perform the adjustment again.
	This message may appear during adjustment when the HMI41 is trying to contact the transmitter.	Wait.
	The connection cable is not properly connected or the serial line settings of the HMI41 and the transmitter do not correspond.	Check the connection of the calibration cable. Check that the serial line settings in the HMI41 memory correspond to those of the transmitter.

Analog Output Tests

HMT120 has a built-in software function for testing the analog outputs. To test the outputs, do the following:

1. Make sure the transmitter is not in adjustment mode.
2. Press the + adjustment button (see Figure 16 on page 50).
This sets the output current level to the high point of the analog output range (20mA nominal). The output stays at this level for about 30 seconds after the + adjustment button has been pressed.
3. Press the - adjustment button (see Figure 16 on page 50).
This sets the output current level to the low point of the analog output range (4mA nominal). The output stays at this level for about 30 seconds after the - adjustment button has been pressed.

HMT120 analog output current can be measured without removing the wires from the screw-terminals by using a low-impedance multimeter between the associated +-terminal and test point (CH1 or CH2) on the component board, see figure 1011-157

Figure 21 below for reference.

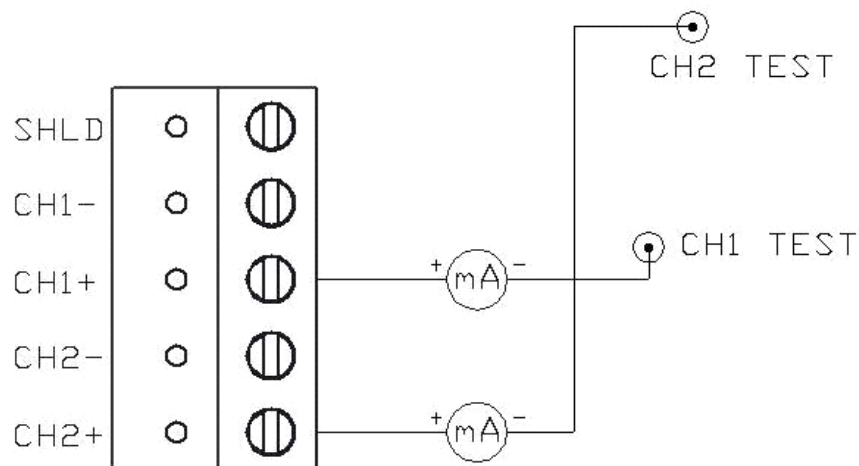

1011-157

Figure 21 HMT120 Output Current Measurement

NOTE

In case of using a HMT120 transmitter with display option, the following texts are shown at the display during analog output test:

"Analog output test high" corresponding to 20mA current output
"Analog output test low" corresponding to 4mA current output

This page intentionally left blank.

CHAPTER 6

TROUBLESHOOTING

This chapter describes error messages and analog output error behavior, troubleshooting for possible problems, and provides contact information for technical support.

Error Codes

HMT120 software includes number of different self diagnostics, such as flash and program memory checksum, probe communication status, probe checksum, operation voltage check, oscillator fault check etc.

At startup software checks factory/user settings checksum, program memory checksum and oscillator fault status. Other checks are made during runtime. Available error codes are shown in the table below.

Table 7 Error Codes and Texts

Code	Description	Error Text
1	Probe T measurement error	Probe T meas
2	Probe RH measurement error	Probe RA meas
3	Probe communication error	Probe communication
4	Probe checksum error	Probe checksum
5	Probe message form error	Probe message form
6	Program's flash checksum error	Program code checksum
7	Current settings checksum error (RAM)	Settings checksum
8	Factory flash not initialised	Factory defaults empty
9	User flash not initialised	User defaults empty
10	Voltage is too low to operate correctly	Voltage too low
11	Measurements not available	Measurements not available
12	Oscillator fault bit active	HW fault 1
13	Analog output quantity invalid	Analog output quantity invalid
14	Display quantity invalid	Display quantity invalid

Error text is shown by using the **ERRS** command via the serial interface. In case of using a HMT120 transmitter with display option the error code is shown at the display in format "**ERR:Code-1[.Code-2][.Code-n]**". Multiple errors are separated with a dot between the error codes.

Solving Typical Problems

You can check the error message via the serial interface by using the **ERRS** command; see section **Error Codes** on page 67. In case of constant error, please contact Vaisala Technical Support.

Table 8 Troubleshooting Table

Problem or Message	Likely Causes and Solutions
Measurement not working, any of the following errors is active: - Probe RH measurement error - Probe T measurement error	- Sensor(s) damaged or missing. Open the probe filter and check. - Calibration is not done. Calibrate the probe. - Check the supply voltage of the transmitter.
Transmitter cannot communicate with the probe, any of the following errors is active: - Probe communication error - Probe checksum error - Probe message form error - Measurements not available	- Check the attachment of the probe to the transmitter. - In case of remote probe, check also the interconnection cables. - Replace the probe if necessary.
Serial line command not working, outputs "Unknown command."	- Mistyped or unknown command, check the command syntax and parameters.
Cannot connect to serial line, current serial settings of the module are unknown.	Perform the following steps to connect: 1. Set your terminal settings to 19200 8 N 1 (the default settings of the transmitter). 2. Connect to the service port of the transmitter. 2. Power up the transmitter, and type "Z" on the serial line at least five times. 4. The transmitter will come online with the default settings. 5. Use the SERI command to set the desired serial settings, and use the SAVE command to save them.
Any of the following errors is active: - Current settings checksum error - Default settings checksum error	Internal error. Perform the following steps: 1. Reset or power cycle the module. Check if the error disappears. 2. Return the module to factory settings using the FRESTORE command. Check again. 3. If the error is still active, contact a Vaisala service center.
Any of the following errors is active: - Program checksum error - Factory flash defaults checksum error - Factory flash not initialized - Oscillator fault bit active	Faulty transmitter, contact a Vaisala service center.
Any of the following errors is active: - Analog output quantity invalid - Display quantity invalid	In case of "Analog output quantity invalid" error select the correct output quantities (set with the CALCS command) with ASEL command and in case of "Display quantity invalid" error select the correct display quantities with DSEL command.

Analog Output Error Notification

If the transmitter is unable to operate due to an error, the analog outputs will be set to an error level.

Default output current in error state is 3.6mA. Error current value can be changed via the serial interface by using the **AERR** command; see section **Set/show Analog Output Error Levels** on page 38.

Technical Support

For technical questions, contact the Vaisala technical support via e-mail at helpdesk@vaisala.com.

For contact information of Vaisala Service Centers, see www.vaisala.com/servicecenters.

This page intentionally left blank.

CHAPTER 7

TECHNICAL DATA

This chapter provides the technical data of the HMT120.

Table 9 Relative Humidity Measurement Specifications

Property	Description / Value
Measurement range	0 ... 100 %RH
Accuracy (including non-linearity, hysteresis, and repeatability): at 0 ... +40 °C (+32 ... +104 °F) at -40 ... 0 °C and +40 ... +80 °C (-40 ... +32 °F and +104...+176 °F)	±1.5 %RH (0 ... 90 %RH) ±2.5 %RH (90 ... 100 %RH) ±3.0 %RH (0 ... 90 %RH) ±4.0 %RH (90 ... 100 %RH)
Factory calibration uncertainty at +20 °C (+68 °F)	±1.5 %RH
Humidity sensor	HUMICAP [®] 180R

Table 10 Temperature Measurement Specifications

Property	Description / Value
Measurement range	-40 ... +80 °C (-40 ... +176 °F)
Accuracy over temperature range: at +15 ... +25 °C (+59 ... +77 °F) at 0 ... +15 °C and +25 ... +40 °C (+32 ... +59 °F and +77 ... +104 °F) at -40 ... 0 °C and +40 ... +80 °C (-40 ... +32 °F and +104...+176 °F)	±0.2 °C (±0.36 °F) ±0.25 °C (±0.45 °F) ±0.4 °C (±0.72 °F)
Temperature sensor	Pt1000 RTD Class F0.1 IEC 60751

Table 11 Operating Environment Specifications

Property	Description / Value
Operating temperature range	
Transmitter body, no display	-40 ... +60 °C (-40 ... +140 °F)
Transmitter body, with display	-20 ... +60 °C (-4 ... +140 °F)
HMP110 probe	-40 ... +80 °C (-40 ... +176 °F)
Storage temperature range	-50 ... +70 °C (-58 ... +158 °F)
Electromagnetic compatibility	EN 61326-1:2006 Electrical equipment for measurement, control and laboratory use - EMC requirements - Basic immunity test requirements. EN 55022:2006 + Am 1:2007 Information technology equipment - Radio disturbance characteristics - Limits and methods of measurement. Class B.

Table 12 Inputs and Outputs

Property	Description / Value
Two-wire output signal	4 ... 20 mA (loop powered)
External loop voltage	10 ... 30 VDC ($R_L = 0$ ohms) 20 ... 30 VDC ($R_L < 500$ ohms)
Max. additional error caused by the analog outputs after calibration at +20 °C ambient temperature	$\pm 0.1\%$ of full scale output current
Temperature dependence of the analog outputs	$\pm 0.005 \%$ /°C full scale output current

Table 13 Mechanical Specifications

Property	Description / Value
Material	
Transmitter housing	PBT plastic
Display window	PC plastic
Probe body	Stainless steel (AISI 316)
Probe grid filter	Chrome coated ABS plastic
Housing classification	IP65 (NEMA 4)
Connections	
Current loop outputs	Screw terminals 0.5 ... 1.5 mm ²
Probe interface	4-pin M8 female panel connector
Probe cable lengths	3 m, 5 m, 10 m, 20 m cables can be cascaded up to 50 m
Display (optional)	128x64 resolution full graphics B&W display without backlight
Weight (Wall model, including probe)	270 g
Weight (10m cable model)	540 g

Options and Accessories

Table 14 Options and Accessories

Description	Order Code
HMP110 probe for HMT120	HMP110 – separate order form
HMP110R replacement probe for HMT120	HMP110R – separate order form
HMP110T temperature only probe for HMT120	HMP110T – separate order form
Constant output probe	HMP110REF – separate order form
Humidity sensor	Humicap180R
Probe mounting flange	226061
Probe mounting clamp, 1 piece	225501
Probe mounting clamp set, 10 pcs	226067
Sensor protection	
Plastic grid filter	DRW010522SP
Plastic grid with membrane filter	DRW010525
Stainless steel sintered filter	HM46670SP
Probe cable 3 m	HMT120Z300
Probe cable 5 m	HMT120Z500
Probe cable 10 m	HMT120Z1000
Probe cable 20 m	HMT120Z2000
Radiation shield	DTR504A
Probe installation kit for DTR504	227777
Rain shield with installation kit	215109
Duct installation kit	215619
HMI41 connection cable	25917ZZ
HM70 connection cable	211339
Service cable for PC, USB	219685

Transmitter Dimensions

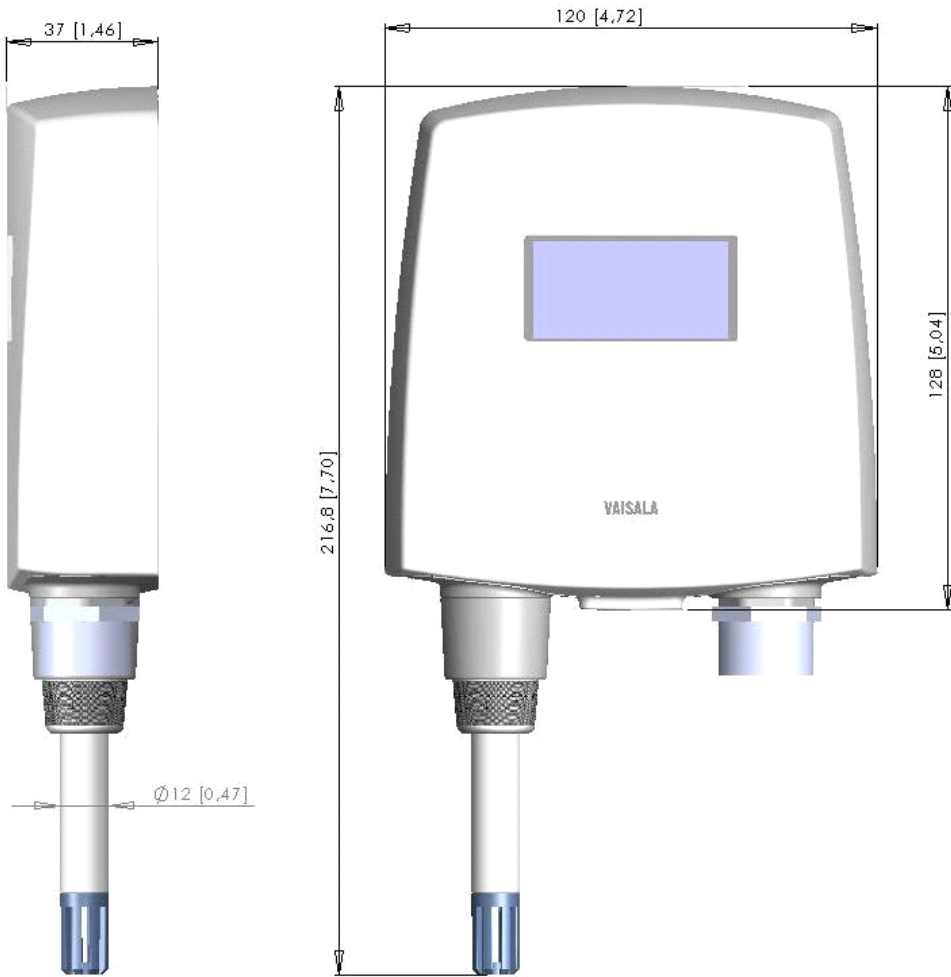

1011-158

Figure 22 Dimensions of the Fixed Probe Model in mm (inches)

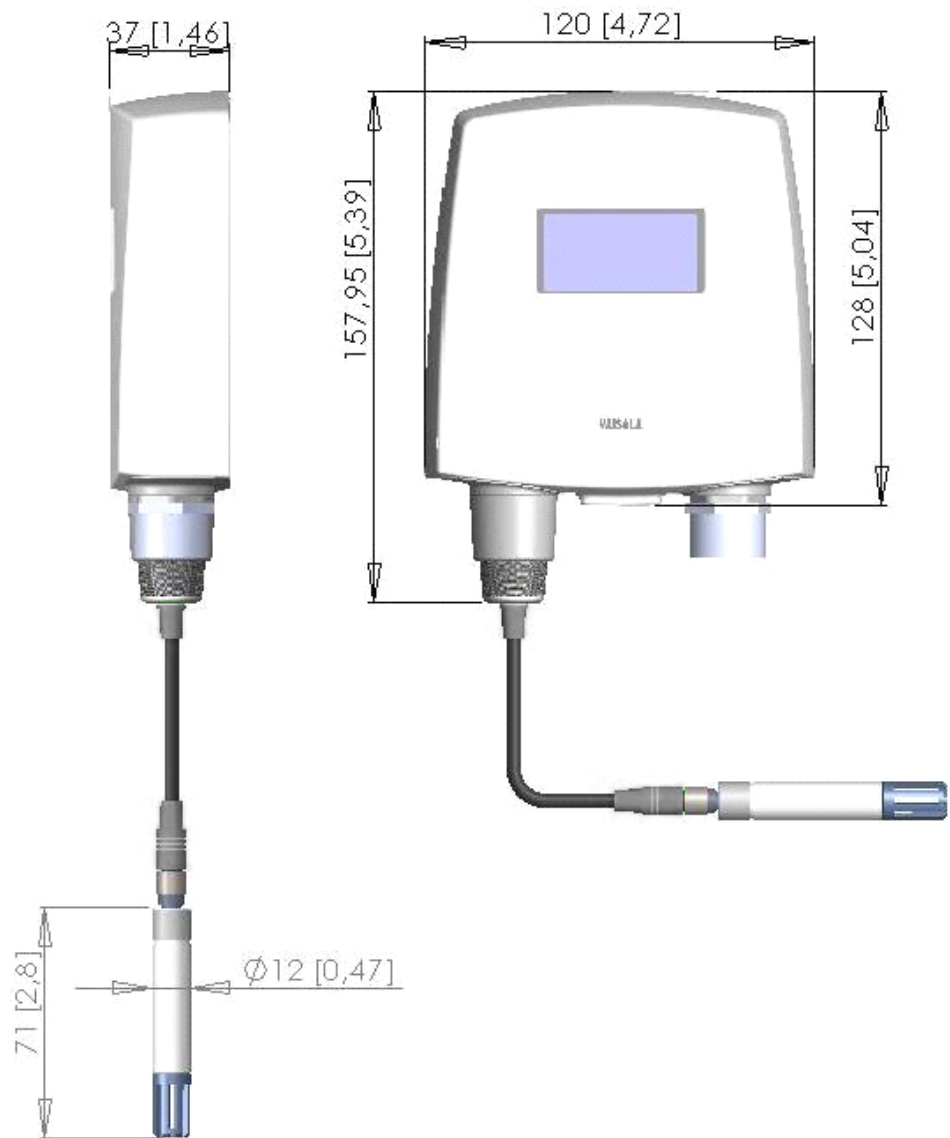

1011-159

Figure 23 Dimensions of the Remote Probe Model in mm (inches)

This page intentionally left blank.

APPENDIX A

CALCULATION FORMULAS

This appendix contains the formulas used for the calculated output quantities.

HMT120 transmitter receives relative humidity and temperature from the HMP110 probe. From these values dewpoint, frostpoint, absolute humidity, mixing ratio, enthalpy, wet bulb temperature, saturation vapor pressure and vapor pressure in normal pressure are calculated using the following equations.

Symbols:

T_d	=	Dewpoint temperature (°C)
P_w	=	Water vapor pressure (hPa)
P_{ws}	=	Saturation vapor pressure (hPa)
RH	=	Relative humidity (%)
x	=	Mixing ratio (g/kg)
p	=	Atmospheric pressure (hPa)
a	=	Absolute humidity (g/m ³)
T	=	Temperature (°C)
h	=	Enthalpy (kJ/kg)
T_w	=	Wet bulb temperature (°C)
T_{df}	=	Dew/frostpoint temperature (°C)

Dewpoint Temperature

The dewpoint temperature (T_d) of a moist air sample is the temperature to which the sample must be cooled to reach saturation with respect to liquid water.

Dewpoint temperature is calculated using:

$$T_d = \frac{T_n}{\frac{m}{\log\left(\frac{P_w}{A}\right)} - 1} \quad [^{\circ}\text{C}] \quad (1)$$

P_w is the water vapor pressure (see the equation below). The parameters A , m , and T_n depend on temperature according to the following table:

T	A	m	Tn
... 0 °C	6.119866	7.926104	250.4138
0 ... 50 °C	6.1078	7.5000	237.30
50 ... 100 °C	5.9987	7.3313	229.10
100 ... 150 °C	5.8493	7.2756	225.00
150 ... °C	6.2301	7.3033	230.00

Dew/frostpoint Temperature

Dew/frostpoint temperature uses frostpoint calculation when the dewpoint is below 0 °C. Frostpoint is the temperature at which the air is saturated with respect to water vapor over an ice surface.

$$T_d \geq 0 \rightarrow T_{df} = T_d$$

$$T_d < 0 \rightarrow T_{df} = \frac{T_n}{\frac{m}{\log\left(\frac{P_w}{A}\right)} - 1} \quad [^{\circ}\text{C}] \quad (2)$$

P_w is the water vapor pressure (see the equation below). The parameters A , m , and T_n depend on temperature according to the following table:

Td	A	m	Tn
... 0 °C	6.1134	9.7911	273.47

Mixing Ratio

The mixing ratio (mass of water vapour/mass of dry gas) is calculated using:

$$x = B \times \frac{P_w}{p - P_w} \quad [g / kg] \quad (3)$$

where:

$$B = 621.9907 \text{ g/kg}$$

The value of B depends on the gas. 621.9907 g/kg is valid for air.

Absolute Humidity

Absolute humidity is defined as the mass of water vapour in a certain volume. If ideal gas behaviour is assumed the absolute humidity can be calculated using:

$$a = C \cdot \frac{P_w}{(T + 273.15)} \quad [g / m^3] \quad (4)$$

where:

$$C = 216.679 \text{ gK/J}$$

Enthalpy

Enthalpy is the sum of the internal energy of a thermodynamic system. It can be calculated from mixing ratio using:

$$h = T \cdot (1.01 + 0.00189 \cdot x) + 2.5 \cdot x \quad [kJ / kg] \quad (5)$$

Saturation Vapor Pressure

The saturation vapor pressure (P_{ws}) is the equilibrium water vapor pressure in a closed chamber containing liquid water. It is a function only of temperature, and it indicates the maximum amount of water that can exist in the vapor state.

The water vapor saturation pressure P_{ws} is calculated by using two equations (6 and 7):

$$\Theta = T - \sum_{i=0}^3 C_i T^i \quad [hPa] \quad (6)$$

where

$$\begin{aligned} T &= \text{Temperature in K} \\ C_i &= \text{coefficients} \\ C_0 &= 0.49313580 \\ C_1 &= -0.46094296 * 10^{-2} \\ C_2 &= 0.13746454 * 10^{-4} \\ C_3 &= -0.12743214 * 10^{-7} \end{aligned}$$

$$\ln P_{ws} = \sum_{i=-1}^3 b_i \Theta^i + b_4 \ln \Theta \quad (7)$$

where

$$\begin{aligned} b_i &= \text{Coefficients} \\ b_{-1} &= -0.58002206 * 10^4 \\ b_0 &= 0.13914993 * 10^1 \\ b_1 &= -0.48640239 * 10^{-1} \\ b_2 &= 0.41764768 * 10^{-4} \\ b_3 &= -0.14452093 * 10^{-7} \\ b_4 &= 6.5459673 \end{aligned}$$

Water Vapor Pressure

Vapor pressure refers to the vapor pressure of water in air or other gas. Water vapor has a partial pressure P_w which is part of the total pressure of the gas.

The water vapor pressure is calculated using:

$$P_w = RH \cdot \frac{P_{ws}}{100} \quad [hPa] \quad (8)$$

Accuracies of Calculated Variables

Accuracies of the calculated variables depend on the calibration accuracy of the humidity and temperature sensors; here the accuracies are given for $\pm 2\%RH$ and $\pm 0.2\text{ }^\circ\text{C}$.

Accuracy of Dewpoint Temperature $^\circ\text{C}$

Temp.	Relative humidity									
	10	20	30	40	50	60	70	80	90	100
-40	1.86	1.03	0.76	0.63	0.55	0.50	0.46	0.43	—	—
-20	2.18	1.19	0.88	0.72	0.62	0.56	0.51	0.48	—	—
0	2.51	1.37	1.00	0.81	0.70	0.63	0.57	0.53	0.50	0.48
20	2.87	1.56	1.13	0.92	0.79	0.70	0.64	0.59	0.55	0.53
40	3.24	1.76	1.27	1.03	0.88	0.78	0.71	0.65	0.61	0.58
60	3.60	1.96	1.42	1.14	0.97	0.86	0.78	0.72	0.67	0.64
80	4.01	2.18	1.58	1.27	1.08	0.95	0.86	0.79	0.74	0.70
100	4.42	2.41	1.74	1.40	1.19	1.05	0.95	0.87	0.81	0.76
120	4.86	2.66	1.92	1.54	1.31	1.16	1.04	0.96	0.89	0.84
140	5.31	2.91	2.10	1.69	1.44	1.26	1.14	1.05	0.97	0.91
160	5.80	3.18	2.30	1.85	1.57	1.38	1.24	1.14	1.06	0.99

Accuracy of Mixing Ratio g/kg (Ambient Pressure 1013 mbar)

Temp.	Relative humidity									
	10	20	30	40	50	60	70	80	90	100
-40	0.003	0.003	0.003	0.003	0.003	0.004	0.004	0.004	—	—
-20	0.017	0.018	0.019	0.021	0.022	0.023	0.025	0.026	—	—
0	0.08	0.09	0.09	0.10	0.10	0.11	0.11	0.12	0.13	0.13
20	0.31	0.33	0.35	0.37	0.39	0.41	0.43	0.45	0.47	0.49
40	0.97	1.03	1.10	1.17	1.24	1.31	1.38	1.46	1.54	1.62
60	2.68	2.91	3.16	3.43	3.72	4.04	4.38	4.75	5.15	5.58
80	6.73	7.73	8.92	10.34	12.05	14.14	16.71	19.92	24.01	29.29
100	16.26	21.34	28.89	40.75	60.86	98.85	183.66	438.56	—	—
120	40.83	74.66	172.36	—	—	—	—	—	—	—

Accuracy of Wet Bulb Temperature °C

Temp.	Relative humidity									
	10	20	30	40	50	60	70	80	90	100
-40	0.20	0.20	0.20	0.20	0.20	0.20	0.20	0.20	—	—
-20	0.21	0.21	0.22	0.22	0.22	0.22	0.23	0.23	—	—
0	0.27	0.28	0.28	0.29	0.29	0.29	0.30	0.30	0.31	0.31
20	0.45	0.45	0.45	0.44	0.44	0.44	0.43	0.43	0.42	0.42
40	0.84	0.77	0.72	0.67	0.64	0.61	0.58	0.56	0.54	0.52
60	1.45	1.20	1.03	0.91	0.83	0.76	0.71	0.67	0.63	0.60
80	2.23	1.64	1.32	1.13	0.99	0.89	0.82	0.76	0.72	0.68
100	3.06	2.04	1.58	1.31	1.14	1.01	0.92	0.85	0.80	0.75
120	3.85	2.40	1.81	1.48	1.28	1.13	1.03	0.95	0.88	0.83
140	4.57	2.73	2.03	1.65	1.41	1.25	1.13	1.04	0.97	0.91
160	5.25	3.06	2.25	1.82	1.55	1.37	1.24	1.13	1.05	0.99

Accuracy of Absolute Humidity g/m³

Temp.	Relative humidity									
	10	20	30	40	50	60	70	80	90	100
-40	0.004	0.004	0.005	0.005	0.005	0.006	0.006	0.006	—	—
-20	0.023	0.025	0.027	0.029	0.031	0.032	0.034	0.036	—	—
0	0.10	0.11	0.12	0.13	0.13	0.14	0.15	0.15	0.16	0.17
20	0.37	0.39	0.41	0.43	0.45	0.47	0.49	0.51	0.53	0.55
40	1.08	1.13	1.18	1.24	1.29	1.34	1.39	1.44	1.49	1.54
60	2.73	2.84	2.95	3.07	3.18	3.29	3.40	3.52	3.63	3.74
80	6.08	6.30	6.51	6.73	6.95	7.17	7.39	7.61	7.83	8.05
100	12.2	12.6	13.0	13.4	13.8	14.2	14.6	15.0	15.3	15.7
120	22.6	23.3	23.9	24.6	25.2	25.8	26.5	27.1	27.8	28.4
140	39.1	40.0	41.0	42.0	43.0	44.0	45.0	45.9	46.9	47.9
160	63.5	64.9	66.4	67.8	69.2	70.7	72.1	73.5	74.9	76.4

INDEX

A			
Accessories	10, 73		
Active Errors			
Display	43		
Analog Output	65		
Calibrate	35		
Configuration	38		
Analog Output Error Levels			
Set	38		
Show	38		
Analog Output Error Notification	69		
Analog Output Quantity and Scaling			
Set	38		
Show	38		
Analog Output Status			
Show	30		
Analog Outputs			
Test	40		
C			
Calibration Commands	33		
Calibration Information			
Set	29		
Show	29		
Command List			
Display	43		
Commands			
Other	41		
Component Board	21		
Components	12		
Connections	21		
Continuous Outputting			
Start	31		
Stop	32		
D			
Device Information	27		
Displayed Quantities			
Set	41		
Show	41		
E			
Environmental Parameters			
Set	37		
Show	37		
Error Codes	67		
F			
Factory Settings			
Restoring	44		
		Firmware Version	
		Show	31
		Fixed and Remote Probe Models	10
		H	
		HM70	6, 50, 54, 58, 73
		HMI41	6, 50, 59, 60, 61, 62, 63, 64, 73
		HMT120	
		Adjustment	50
		Calibration	50
		Dimensions	74
		Introduction	9
		Reset	44
		HMT120H	9
		HMT120T	9
		HUMICAP®	
		Replacing	47
		Humidity and Temperature Transmitter	
		Introduction	9
		Humidity Measurement	
		Calibrate	33
		I	
		Installation	
		Duct	17
		Opening	13
		Radiation Shield	16
		Rain Shield	15
		Wall mounting	14
		Interchangeable Probe	10
		L	
		LCD display	10, 21
		M	
		Measurement Parameters	
		Configuration	37
		O	
		Options	10, 12, 73
		Output Formatting	
		Set	42
		Show	42
		Output Interval	
		Set	32
		Show	32
		Output quantities	9
		Output Unit	
		Set	45
		Show	45

P		Serial Line Output Commands	31
Probe Mounting Clamp	20	Serial Line Settings	
Probe Mounting Flange	19	Set	36
Probe RH		Show	36
Restore Factory Calibration	34	Service Port	23
Probe T		Settings	
Restore Factory Calibration	35	Restoring	44
PuTTY	24	Saving	43
Q		System Information	
Quantity		Show	31
Set	28	T	
Show available	28	Technical Support	69
R		Temperature Measurement	
Radiation Shield	16	Calibrate	34
Rain Shield	15	Terminal Application Settings	24
Reading Output		Terminal Echo	
Once	32	Set	36
S		Show	36
Safety	7	Transmitter	
Serial Commands	26	Reset	44
Serial Interface Mode		U	
Set	37	USB Cable	
Show	37	Driver installation	23
Serial Line Operation		W	
Configuration	36	Warranty	8

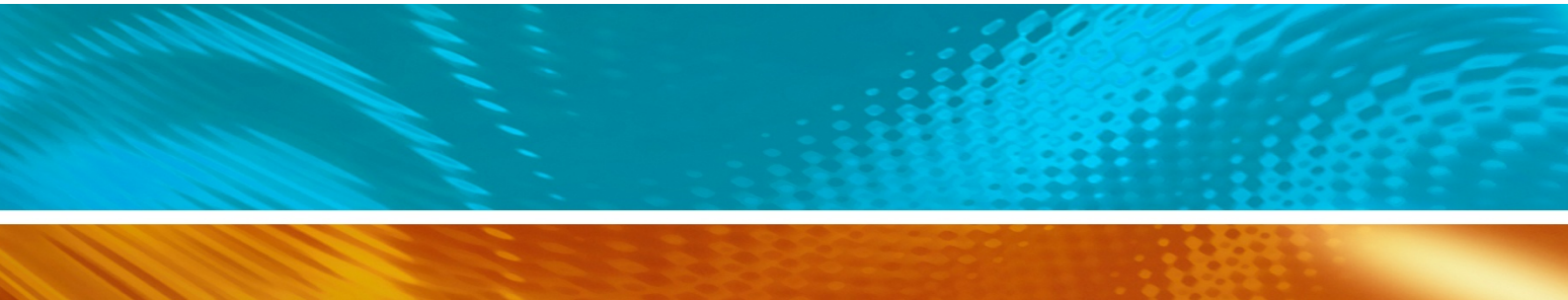

www.vaisala.com

